

Owner's Manual & Assembly Guide



SpaceMaker® Patio Shed

Model No. PS43 CY43T21
CY43JB22

arrowshed.com

Visit our website for compatible accessories

4' x 3'

Nominal Size

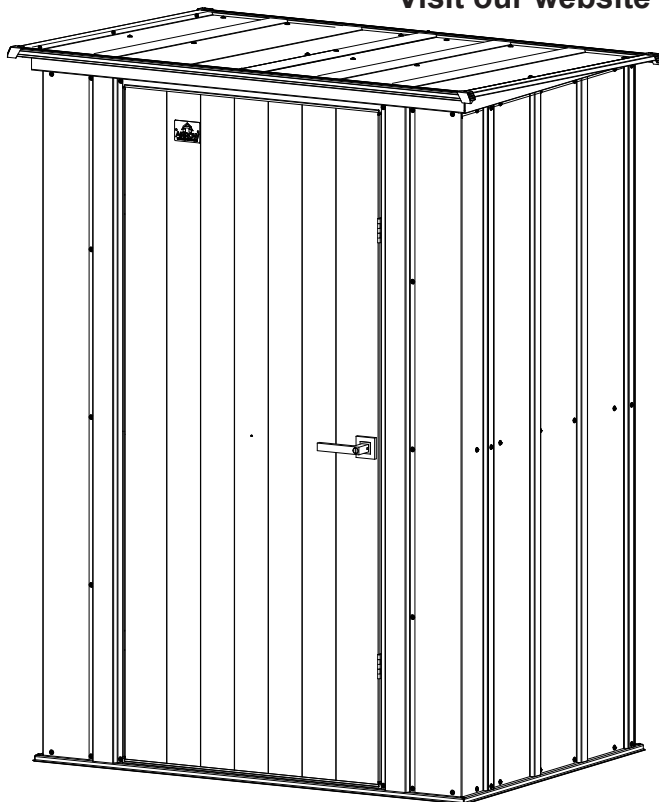

OPTION-A

Register • Enregistrer • Registrare

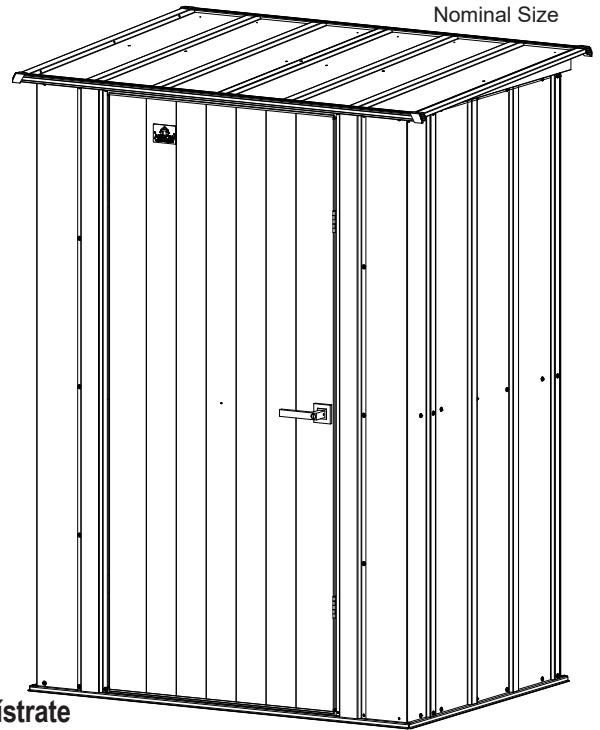

OPTION-B

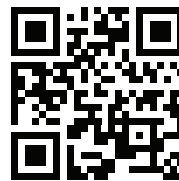

ShelterLogic.com/product-registration

Base Size	52 5/16" x 38 3/8" 132,9 cm x 97,4 cm
------------------	--

For proper base construction see page 11

BUILDING DIMENSIONS

† Size rounded off to the nearest foot

Approx. † Size	Storage Area		Exterior Dimensions (Roof Edge to Roof Edge)			Interior Dimensions (Wall to Wall)			Door Opening	
			Width	Depth	Height	Width	Depth	Height	Width	Height
4' x 3'	12 Sq. Ft.	74 Cu. Ft.	54 3/4"	39 1/4"	74 1/4"	49 1/2"	35 9/16"	73 11/16"	30 7/16"	69 11/16"
1,2 m x ,9 m	1,1 m ²	2,1 m ³	139,1 cm	99,7 cm	188,6 cm	125,8 cm	90,3 cm	187,2 cm	77,3 cm	177,0 cm

* See Inside for Detailed Safety Information.

Visitez notre site Web pour des accessoires compatibles

Manuel de l'utilisateur et guide d'assemblage



Taille de la base	52 5/16" x 38 3/8" 132,9 cm x 97,4 cm
-------------------	--

DIMENSIONS DU COFFRE

†Dimension arrondie au pied le plus proche

Taille † approx.	Zone d'entreposage		Dimensions extérieures (de bordure de toit à bordure de toit)			Dimensions intérieures (de paroi à paroi)			Ouverture de porte	
			Largeur	Profondeur	Hauteur	Largeur	Profondeur	Hauteur	Largeur	Hauteur
4' x 3'	12 Sq. Ft.	74 Cu. Ft.	54 3/4"	39 1/4"	74 1/4"	49 1/2"	35 9/16"	73 11/16"	30 7/16"	69 11/16"
1,2 m x ,9 m	1,1 m ²	2,1 m ³	139,1 cm	99,7 cm	188,6 cm	125,8 cm	90,3 cm	187,2 cm	77,3 cm	177,0 cm

* Voir les informations de sécurité détaillées à l'intérieur.

Para accesorios compatibles, visite nuestro sitio web

Manual del propietario e instrucciones de ensamblaje



Tamaño básico	52 5/16" x 38 3/8" 132,9 cm x 97,4 cm
---------------	--

DIMENSIONES DE LA UNIDAD

† Las medidas están redondeadas en pies

Tamaño † aproximado	Área de almacenaje		Dimensiones exteriores (borde a borde del techo)			Dimensiones interiores (pared a pared)			Abertura de la puerta	
			Ancho	Profundidad	Altura	Ancho	Profundidad	Altura	Ancho	Altura
4' x 3'	12 Sq. Ft.	74 Cu. Ft.	54 3/4"	39 1/4"	74 1/4"	49 1/2"	35 9/16"	73 11/16"	30 7/16"	69 11/16"
1,2 m x ,9 m	1,1 m ²	2,1 m ³	139,1 cm	99,7 cm	188,6 cm	125,8 cm	90,3 cm	187,2 cm	77,3 cm	177,0 cm

* Consulte en el interior para obtener la seguridad de información detallada.

CAUTION / ATTENTION / PRECAUCIONES

EN,FR,SP-04HN

- Care must be taken when handling various pieces of your building since many contain sharp edges.
- Faire preuve de précaution pour manipuler les différentes pièces de l'abri car elles présentent de nombreux bords coupants.
- Tenga cuidado al manipular las diferentes piezas de la estructura ya que pueden tener bordes filosos.

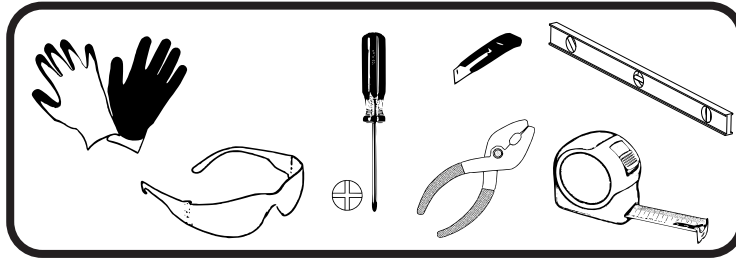

- Do NOT attempt to assemble your building before double checking that you have all the parts indicated in the parts lists. Any building left partially assembled may be seriously damaged by even light winds.
- Ne PAS tenter d'assembler l'abri avant d'avoir vérifié la présence de toutes les pièces figurant dans la liste des pièces. Tout abri laissé partiellement assemblé peut être gravement endommagé par des vents même légers.
- NO trate de montar la estructura antes de verificar que tenga todas las piezas indicadas en la lista de piezas. Cualquier estructura sin terminar puede ser dañada seriamente incluso por vientos ligeros.
- Do NOT attempt to assemble your building on a windy day. The large panels can catch the wind like a "sail", making construction difficult and unsafe. **Watch the Weather Closely**
- Ne PAS tenter d'assembler l'abri en présence de vent. Les grands panneaux peuvent se comporter comme une voile et « battre » au vent, rendant la construction difficile et dangereuse. **Suivre la météo avec attention**
- NO trate de montar la estructura en un día ventoso. Los paneles grandes pueden atrapar el viento como una "vela", lo que hace que sean llevados por el viento, lo que, a su vez, hace que la construcción sea difícil e insegura. **Observe el clima atentamente**
- Keep children and pets away from the worksite during construction and until the building is completely assembled. This will help avoid distractions and any accidents which may occur.
- Tenir les enfants et les animaux domestiques à l'écart du chantier durant la construction et jusqu'à ce que l'abri soit complètement assemblé. Cela évite les distractions et les accidents potentiels.
- No permita entrar a niños ni animales domésticos en el lugar de trabajo durante la construcción y hasta que la estructura esté completamente montada. Esto ayudará a evitar distracciones y cualquier accidente que pueda producirse.
- NEVER concentrate your weight on the roof of the building.
- NE JAMAIS concentrer son propre poids sur le toit de l'abri.
- NUNCA concentre su peso en el techo de la estructura.
- Before assembling any parts, your base should be constructed and an anchoring system should be ready to use. Your building MUST be anchored to prevent wind damage.
- Avant de commencer à assembler des pièces, la base doit avoir été construite et le système d'ancrage doit être prêt à l'emploi. L'abri doit IMPÉRATIVEMENT être ancré pour éviter les dommages par le vent.
- Antes de montar cualquier pieza, debe estar construida la base y preparado el sistema de anclaje. La estructura DEBE estar anclada para evitar daños por vientos.

ASSEMBLY / ASSEMBLAGE / ENSAMBLAR /

- The best location is a level area with good drainage.
- Le meilleur emplacement sera une surface de niveau à bon drainage.
- El mejor lugar es un área nivelada con buen drenaje.
- Allow enough space outside the building to be able to access the roof with a ladder.
- Laissez suffisamment d'espace à l'extérieur du bâtiment pour être en mesure d'accéder à la toiture avec une échelle.
- Deje suficiente espacio afuera del edificio para poder tener acceso al techo con una escalera.
- **Use Teamwork:** Two or more people are required to assemble your building.
- **Travailler en équipe:** Deux personnes ou plus sont nécessaires pour assembler l'abri.
- **Trabaje en equipo:** Se necesitan dos o más personas para ensamblar su cobertizo.

CARE & MAINTENANCE / SOINS ET ENTRETIEN / PROTECCIÓN Y CONSERVACIÓN

- DO NOT use power washing to clean your shed.
- NE PAS utiliser de jet sous haute pression pour nettoyer l'abri.
- NO utilice hidrolavadora para limpiar el cobertizo.
- Combustibles and corrosives must be stored in air tight containers designed for chemical and/or combustible storage. Corrosive chemicals such as fertilizers, pesticides and herbicides should be cleaned off the interior and exterior surfaces immediately. Rust caused by chemical damage is not covered by the warranty.
- Les matières combustibles et corrosives doivent être entreposées dans des contenants étanches à l'air conçus pour l'entreposage de produits chimique et/ou combustibles. Les produits chimiques corrosifs tels que les engrais, pesticides et herbicides doivent immédiatement être nettoyés des surfaces intérieures et extérieures. La rouille causée par des produits chimiques n'est pas couverte par la garantie.
- Los combustibles y productos corrosivos deben guardarse en contenedores herméticos diseñados para almacenamiento de químicos o combustibles. Se deben limpiar inmediatamente los químicos corrosivos, como fertilizantes, pesticidas y herbicidas, de las superficies interiores y exteriores. El óxido causado por daños químicos no está cubierto por la garantía.





Rust protection precautions / Des mesures de protection contre la rouille / Las precauciones de protección contra el óxido

- Avoid nicking or scraping the coating surface, inside and out.
- Éviter d'entailler ou de rayer le revêtement de surface, à l'intérieur comme à l'extérieur.
- Evite dañar o raspar la capa protectora, por dentro y por fuera.
- Keep roof, base perimeter and door free of debris.
- Nettoyer le toit, le pourtour de la base et les rails de porte de tous débris.
- Mantenga el techo, el perímetro de la base y los rieles de la puerta sin desechos.
- Touch up scrapes or nicks and any area of visible rust as soon as possible.
- Retoucher les entailles et égratignures et toute surface de rouille visible dès que possible.
- Retoque las raspaduras o las muescas y cualquier área de todo óxido visible lo más pronto posible.

HARDWARE LIST

LISTE DE LA VISSERIE
LISTA DE PIEZAS

EN,FR,SP-05KY

Key No. Rep. N.º de referencia	Part No. Réf. pièce N.º de pieza	Part Description	Description de la pièce	Descripción de la pieza	Qty. Qté Cant.	Part Views Profils de pièces Vistas desde un extremo
1	65103	Hex Nut (#8-32)	Écrou hexagonal (8-32)	Tuerca hexagonal (N.º 8-32)	34	
2	65923	Small Bolt (#8-32 x 3/8) (10 mm)	Petit boulon (8-32 x 3/8) (10 mm)	Perno pequeño color arena (N.º 8-32 x 3/8) (10 mm)	22	
3	65004	Small Screw (#8AB x 5/16) (8 mm)	Petite vis (8AB x 5/16) (8 mm)	Tornillo pequeño color arena (N.º 8AB x 5/16) (8 mm)	135	
4	66783	Flat Head Bolt (#8-32 X 1/2) (13 mm)	Boulon à tête plate (#8-32 X 1/2) (13 mm)	Perno de cabeza chata (N.º 8-32 x 1/2) (13 mm)	12	
5	66692	Tapping Screw (#10ABx1) (25 mm)	Vis autotaraudeuse (#10ABx1) (25 mm)	Tornillo autorroscante (N.º 10AB x 1) (25 mm)	1	

The fasteners used in each step are shown actual size at the top of each page. If you are unsure which fastener to use, hold it up to the picture and use the one that matches.







Les éléments de visserie utilisés à chaque étape sont représentés en taille réelle en haut de chaque page. En cas de doute sur le type de visserie à utiliser, les placer sur l'image et utiliser celui qui correspond.

Los tornillos y pernos que se utilizan en cada paso se muestran en el tamaño real en la parte superior de cada página. Si no está seguro de qué tornillo o perno de usar, compárelo con la imagen y use el que coincida con ella.

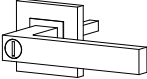
HARDWARE LIST

LISTE DE LA VISSERIE
LISTA DE PIEZAS

EN,FR,SP-06KY

Key No. Rep. N.º de referencia	Part No. Réf. pièce N.º de pieza	Part Description	Description de la pièce	Descripción de la pieza	Qty. Qté Cant.	Part Views Profils de pièces Vistas desde un extremo
6	30000	Locking Handle Right	Poignée verrouillable droite	Manija de bloqueo derecha	1	
7	66609	Hinge	Charnière	Bisagra	2	
8	66183L	Corner Cap	Coin bouchon	Tapa de esquina	2	
9	66183R	Corner Cap	Coin bouchon	Tapa de esquina	2	
10	67236	Adhesive Pads (2 per sheet)	Tampons adhésifs (2 par feuille)	Almohadillas adhesivas (2 por hoja)	1	
11	66646	Washer Sheet	Plaque de rondelles	Plancha de arandelas	4	
12	30028	Nameplate	Plaque signalétique	Placa de identificación / Typenschild	1	

PARTS LIST

LISTE DES PIÈCES
ARTÍCULOS DE FERRETERÍA







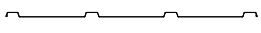

EN,FR,SP-07KY

Key No. Rep. N.º de referencia	Part No. Réf. pièce N.º de pieza	Part Description	Description de la pièce	Descripción de la pieza	Qty. Qté Cant.	Part Views Profils de pièces Vistas desde un extremo
13	11265	Front/Rear Floor Frame	Cadre de plancher avant/arrière	Tirante del entramado delantero/trasero del piso	2	
14	11243	Side Floor Frame	Cadre de plancher latéral	Tirante lateral del piso	2	
15	11276	Ramp	Seuil	Rampa	1	
16	11244	Rear Corner Panel	Panneau de coin arrière	Panel esquinero trasero	2	
17	11266	Front Corner Panel	Panneau d'angle avant	Panel de la delantero esquina	2	
18	6521	Wall Panel	Panneau de mur	Panel de la pared	2	
19	11246	Door Jamb Right	Jambage de porte droit	Jamba de la puerta derecha	1	
20	80179	Door Jamb Left	Jambage de porte gauche	Jamba de la puerta izquierda	1	
21	11275	Rear Wall Channel	Longeron de mur	Canaleta de la pared	1	
22	11262	Side Wall Channel	Longeron de mur latéral	Canal de la pared lateral	2	
23	11271	Rear Wall Angle	Cornière arrière	Ángulo de la pared trasera	1	
24	11267	Lintel	Linteau	Dintel	1	
25	11270	Header	Traverse frontale	Dintel frontal	1	
26	11268	Right Gable	Pignon droit	Gablete derecho	1	
27	80185	Left Gable	Pignon gauche	Gablete izquierdo	1	

PARTS LIST

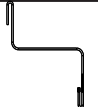
LISTE DES PIÈCES
ARTÍCULOS DE FERRETERÍA

EN,FR,SP-08KY

Key No. Rep. N.º de referencia	Part No. Réf. pièce N.º de pieza	Part Description	Description de la pièce	Descripción de la pieza	Qty. Qté Cant.	Part Views Profils de pièces Vistas desde un extremo
28	11272	Roof Beam /	Poutre de toit /	Viga del techo	1	
29	11251	Right Roof Panel /	Panneau de toit droit /	Panel del techo derecho	1	
30	80181	Left Roof Panel /	Panneau de toit gauche /	Panel del techo izquierdo	1	
31	11273	Roof Trim /	Garniture de toit /	Contramarco del techo	2	
32	80255	Door Panel /	Panneau porte /	Panel puerta	1	
33	10718	Horizontal Door Brace /	Renfort horizontal de porte /	Abrazadera horizontal de la puerta	2	
34	10719	Door Handle Brace /	Renfort de poignée de porte /	Abrazadera de la manija de la puerta	1	
35	10720	Diagonal Door Brace /	Renfort diagonal de porte /	Abrazadera diagonal de la puerta	4	
36	69836	Edge Trim (Purple) /	Garniture de bord /	Recuadro del borde (morado)	2	

ASSEMBLY BY KEY NO. *PIÈCES PAR N° DE REPÈRE* *MONTAJE POR N.º DE REFERENCIA*

EN,FR,SP-09KY

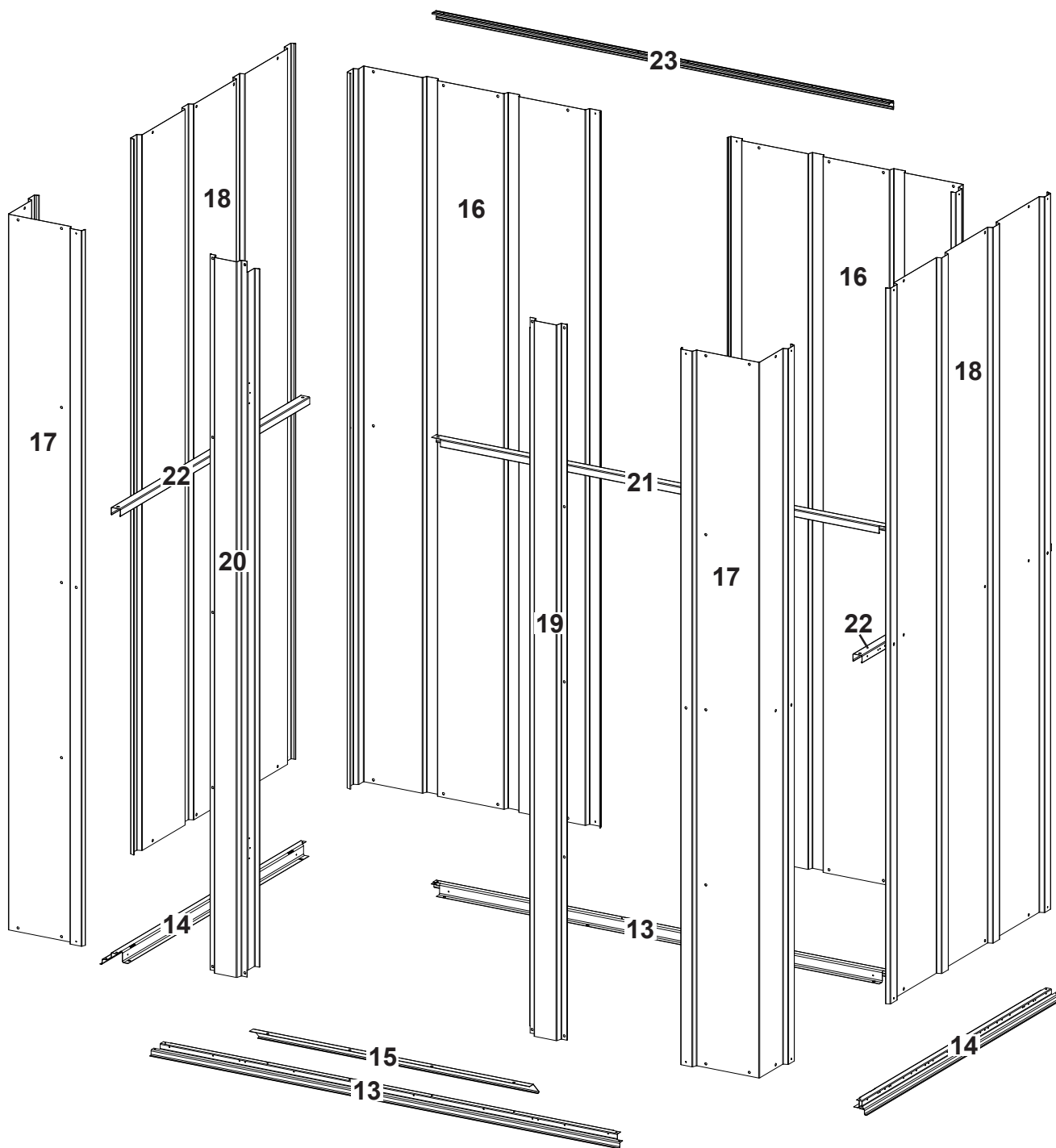

ASSEMBLY BY KEY NO.

PIÈCES PAR N° DE REPÈRE
MONTAJE POR N.º DE REFERENCIA

EN,FR,SP-10KY

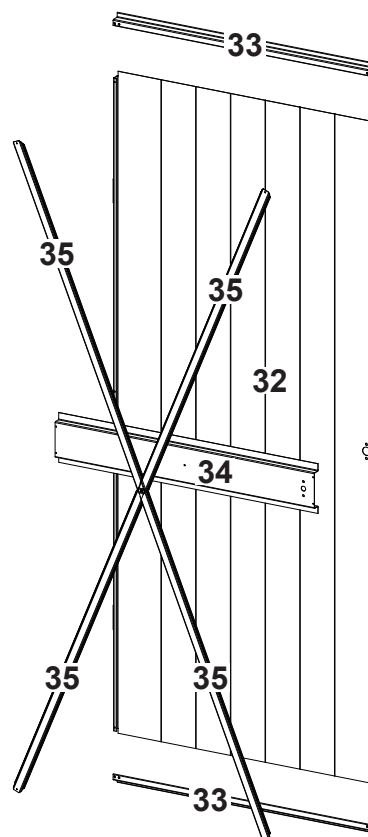
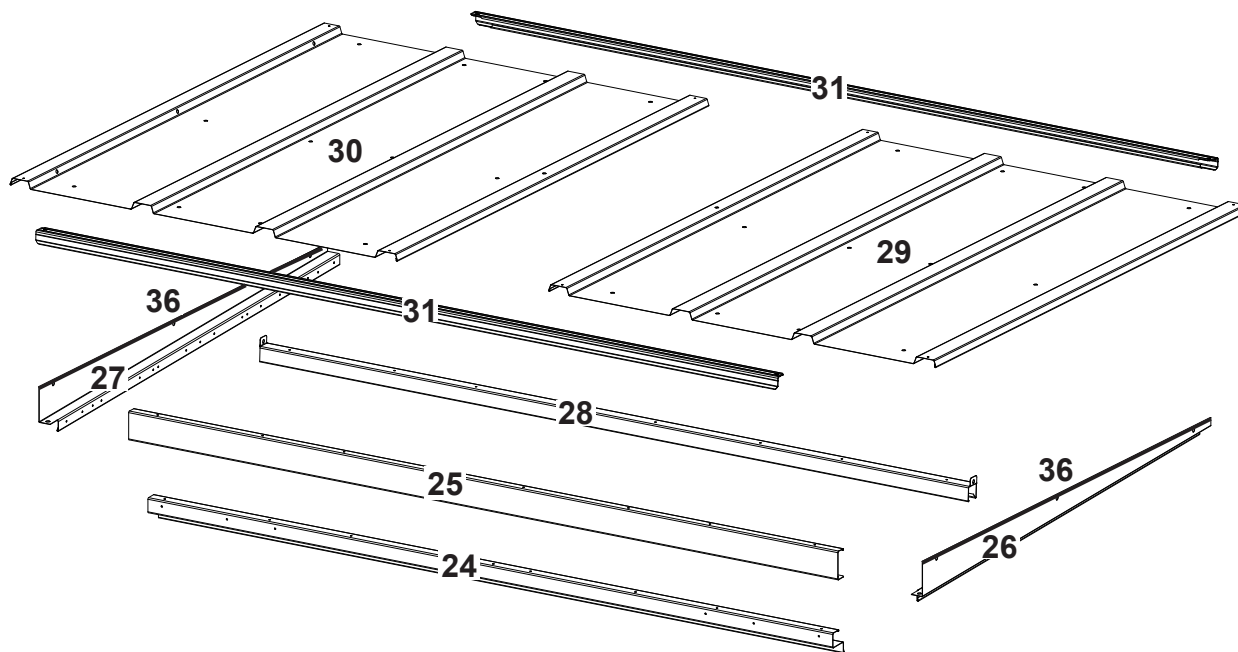

Wood Platform / Plateforme en bois

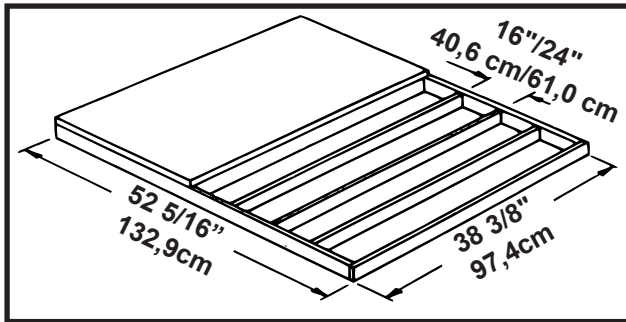

Concrete Slab / Dalle en béton

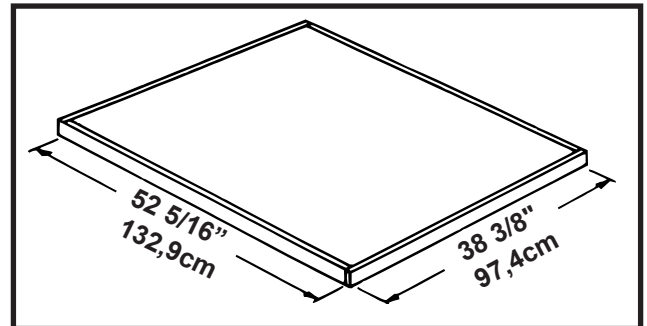

* IMPORTANT *

The base **MUST** be flat and level to provide adequate support for your building, otherwise the **PRE-DRILLED HOLES WILL NOT ALIGN AND IT CANNOT BE ASSEMBLED**. No matter which of the options below you choose for a base, an **ARROW ANCHORING KIT** is recommended as an effective method of properly securing your building after assembly is complete.

OPTION 1: Build directly on the ground

OPTION 2: Wood Platform

NOTE: Pressure Treated Lumber must **NOT** be used where it will make contact with your storage building. The properties of Pressure Treated Lumber will cause accelerated corrosion. **If Pressure Treated Lumber comes in contact with your storage building your warranty will be voided.** The platform should be level and flat (free of bumps, ridges, etc.) to provide good support for the building. The necessary materials may be obtained from your local lumber yard.

OPTION 3: Concrete Slab

The slab should be at least 4" (10,2 cm) thick.

* IMPORTANT *

La base **DOIT** être plate et de niveau pour fournir un support adéquat à votre bâtiment, sinon les trous **PRÉ-PERCÉS NE S'ALIGNERONT PAS ET ILS NE POURRONT PAS ÊTRE ASSEMBLÉS**. Quelque que soit l'option ci-dessous choisie pour la base, un **NÉCESSAIRE D'ANCRAGE ARROW** est recommandé pour amarrer solidement l'abri une fois que le montage est terminé.

OPTION 1 : Construire à même le sol

OPTION 2 : Plateforme en bois

REMARQUE : Ne **PAS** utiliser de bois traité sous pression aux points de contact avec l'abri. **Le bois traité sous pression contribue à accélérer la corrosion. Le contact de bois traité sous pression avec l'abri aura pour effet d'annuler la garantie.** La plateforme doit être plate et de niveau (sans bosses, arêtes, etc.) afin d'offrir un bon support à l'abri. Les matériaux nécessaires peuvent s'obtenir auprès d'un fournisseur de bois d'œuvre local.

OPTION 3 : Dalle en béton

La dalle doit avoir au moins 4 "(10,2 cm) d'épaisseur.

Plataforma de Madera

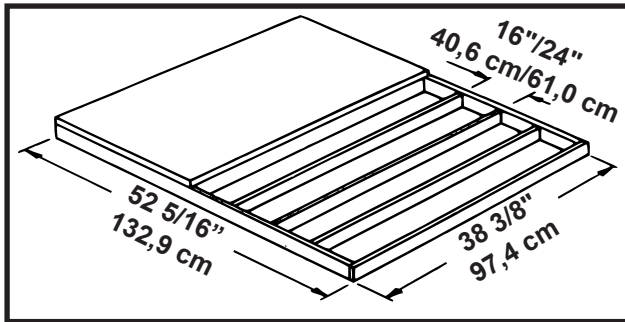

Losa de Hormigón

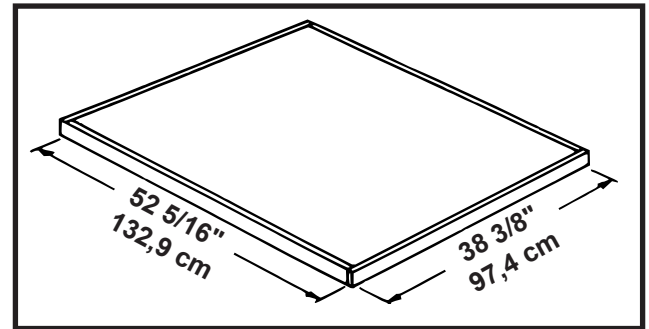

* IMPORTANTE *

La base **DEBE** ser plana y nivelada para proporcionar el soporte adecuado para su edificio; de lo contrario, los **AGUJEROS PRETALDRADOS NO SE ALINEARÁN Y NO SE PUEDEN MONTAR**. Independientemente de las siguientes opciones que elija como base, se recomienda un KIT DE SUJECIÓN ARROW como método eficaz para sujetar adecuadamente su cobertizo después de terminar el ensamblaje.

OPCIÓN 1: Construir directamente en el suelo

OPCIÓN 2: Plataforma de madera

NOTA: La madera tratada a presión **NO** debe usarse donde haga contacto con su edificio de almacenamiento. Las propiedades de la madera tratada a presión causarán corrosión acelerada. **Si la madera tratada a presión entra en contacto con su edificio de almacenamiento, su garantía quedará anulada.** La plataforma debe estar nivelada y plana (libre de golpes, crestas, etc.) para proporcionar un buen soporte para el edificio. Los materiales necesarios se pueden obtener de su aserradero local.

OPCIÓN 3: Losa de hormigón

La losa debe tener **al menos 4" (10,2 cm)** de espesor.

1: FLOOR FRAME

CADRE DE PLANCHER
MARCO DE PISO

EN,FR,SP-13KY

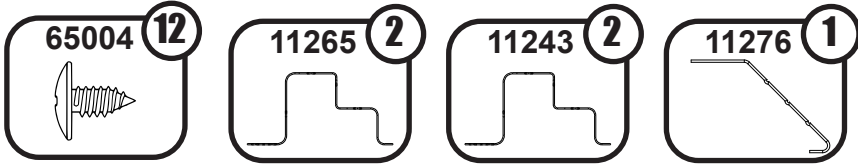

NOTES:

Do NOT fasten your Floor Frames to your Base at this time. You will anchor your building after it is erected.

The Floor Frame must be BOTH square AND level or the holes will not line up properly.

Measure diagonally from corner to corner. When diagonal measurements are equal, the Frame is square.

REMARQUES:

Ne PAS attacher les éléments de cadre de plancher à la base à ce stade. L'abri sera ancré une fois qu'il est assemblé.

Le cadre de plancher doit être À LA FOIS d'équerre et de niveau pour que les trous s'alignent correctement.

Mesurer en diagonale d'un coin à l'autre. Lorsqu'elles sont égales, le cadre de plancher est d'équerre.

NOTAS:

NO fije los tirantes del piso a la base en este momento. Anclará la estructura después de que esté erguida.

El tirante del piso debe estar TANTO cuadrado COMO nivelado o los orificios no se alinearán correctamente.

Mida diagonalmente de esquina a esquina. Cuando las medidas diagonales son iguales, el tirante está cuadrado.

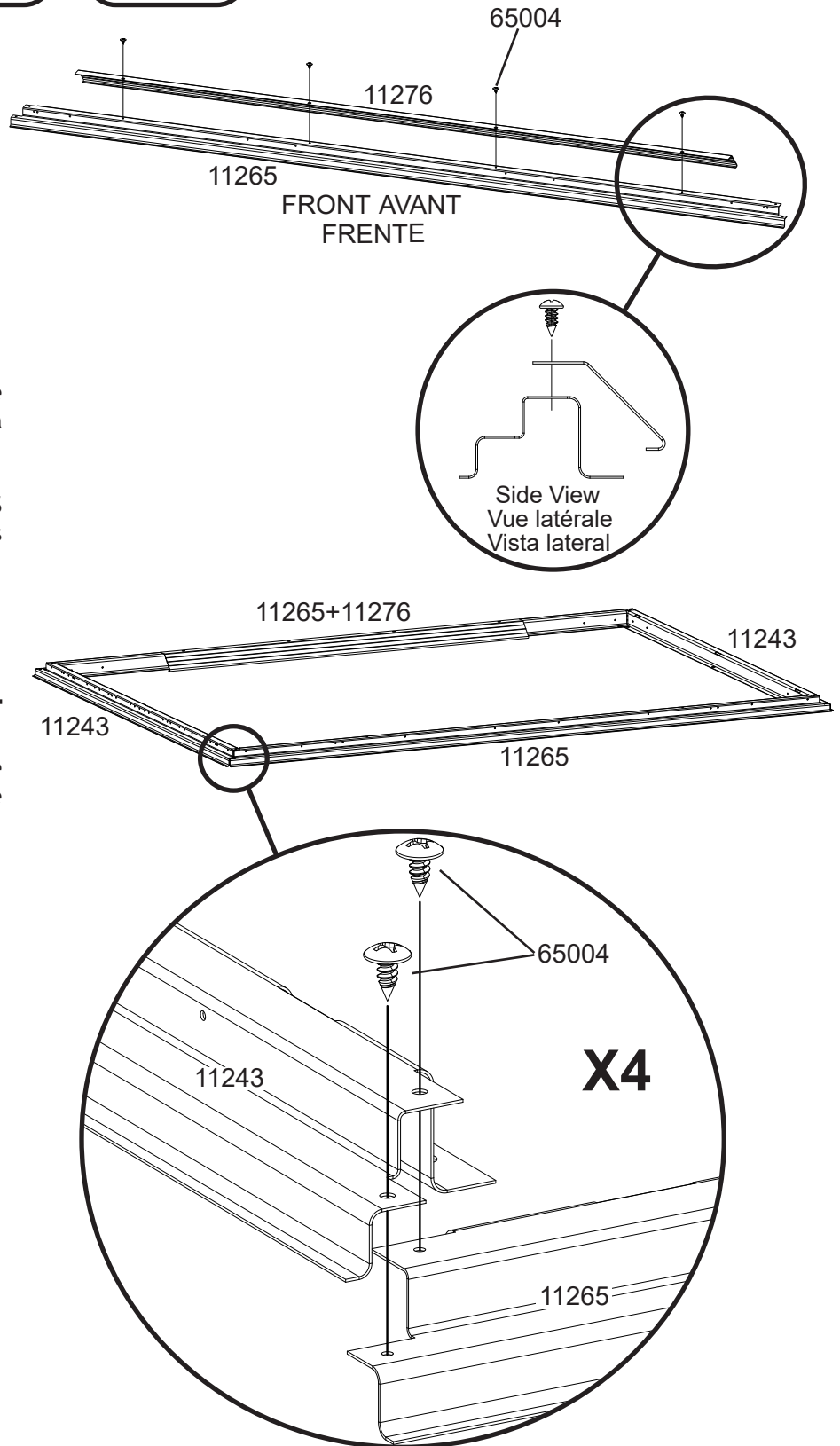

Panel Layout / Diseño del panel / Schéma du panneau

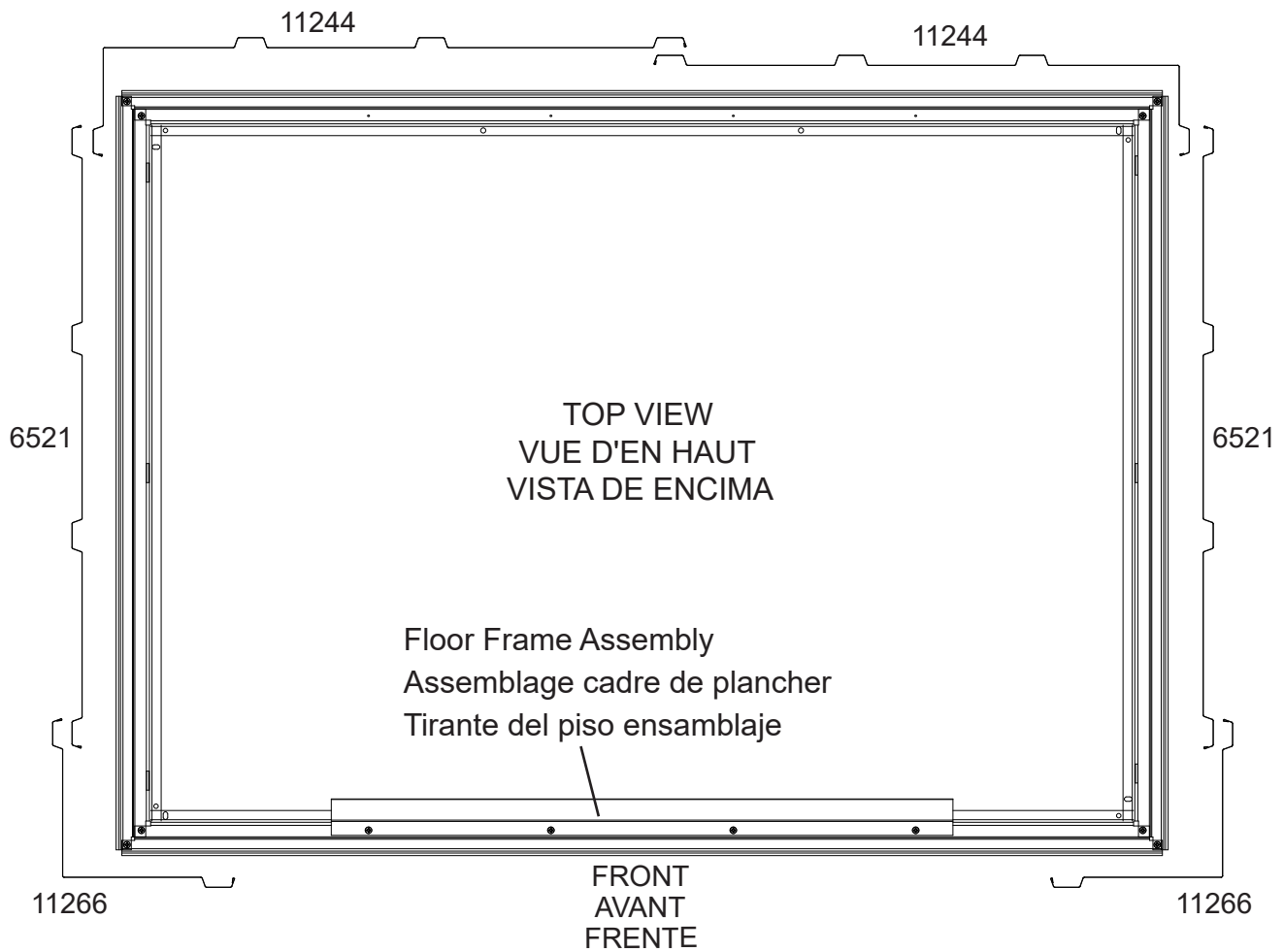

2: WALL PANELS

PANNEAUX DE MUR
PANELES DE LA PARED

EN,FR,SP-15KY

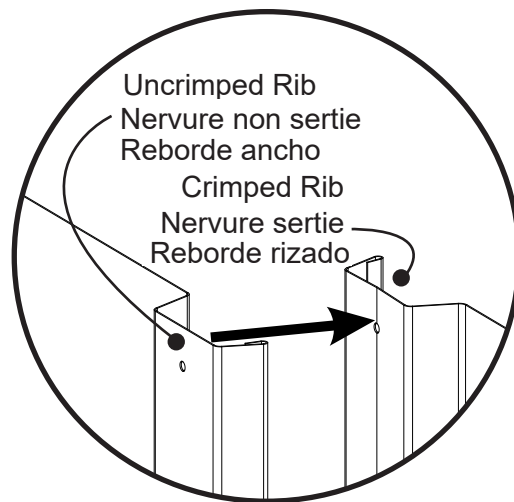
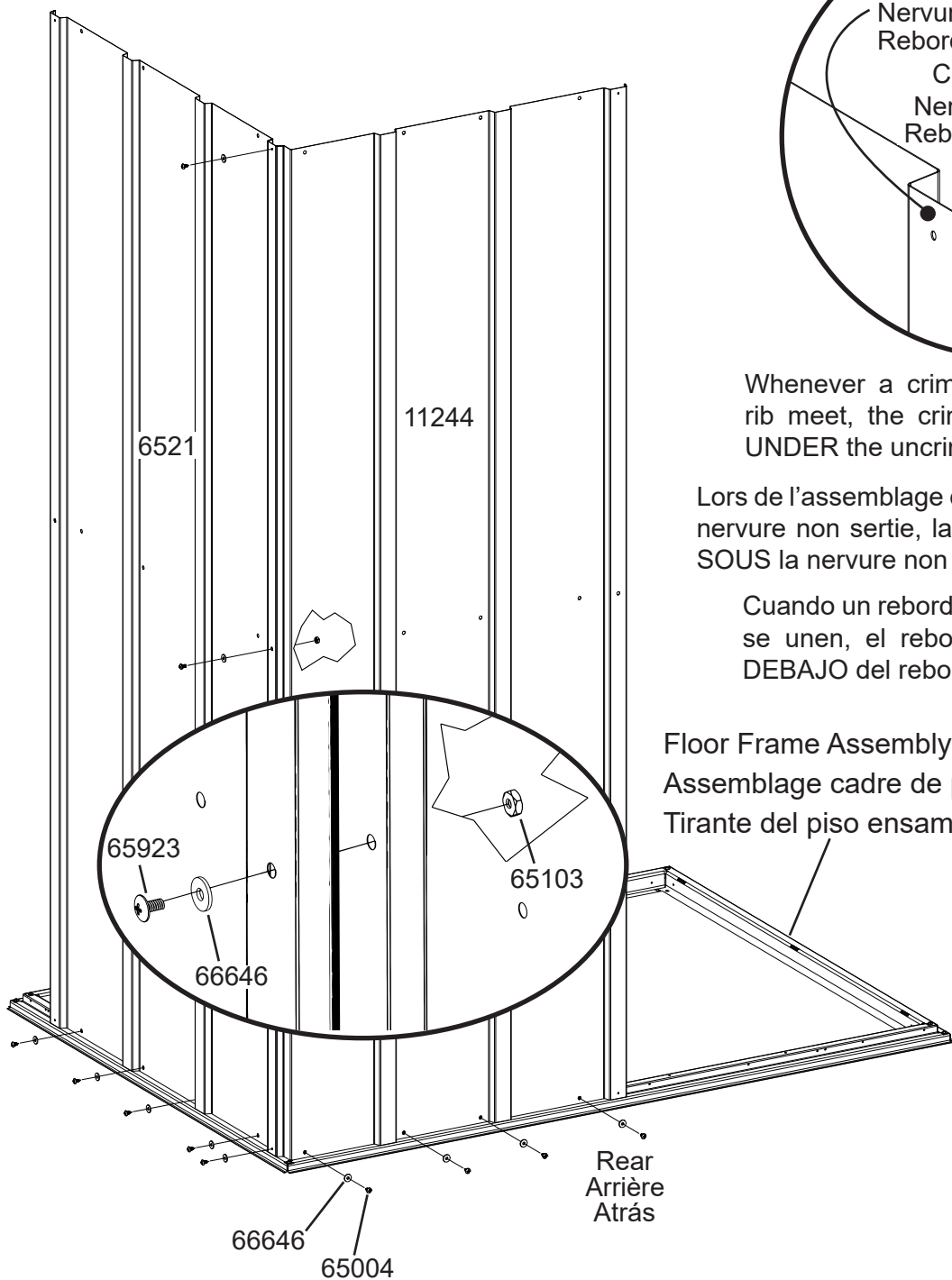
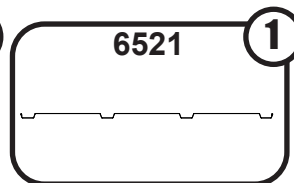
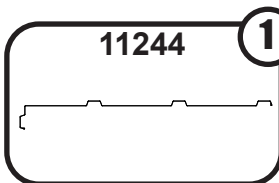
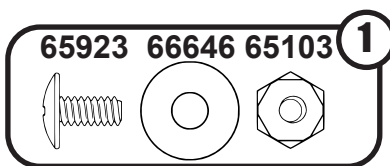
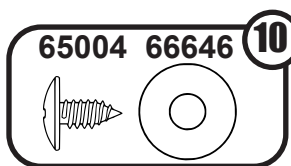

Whenever a crimped rib and an uncrimped rib meet, the crimped rib should be placed **UNDER** the uncrimped rib if possible.

Lors de l'assemblage de toute nervure sertie avec une nervure non sertie, la nervure sertie doit être placée **SOUS** la nervure non sertie autant que possible.

Cuando un reborde rizado y un reborde ancho se unen, el reborde rizado debe colocarse **DEBAJO** del reborde ancho, si es posible.

Floor Frame Assembly
Assemblage cadre de plancher
Tirante del piso ensamblaje

Rear
Arrière
Atrás

2: WALL PANELS

PANNEAUX DE MUR
PANELES DE LA PARED

EN,FR,SP-16KY

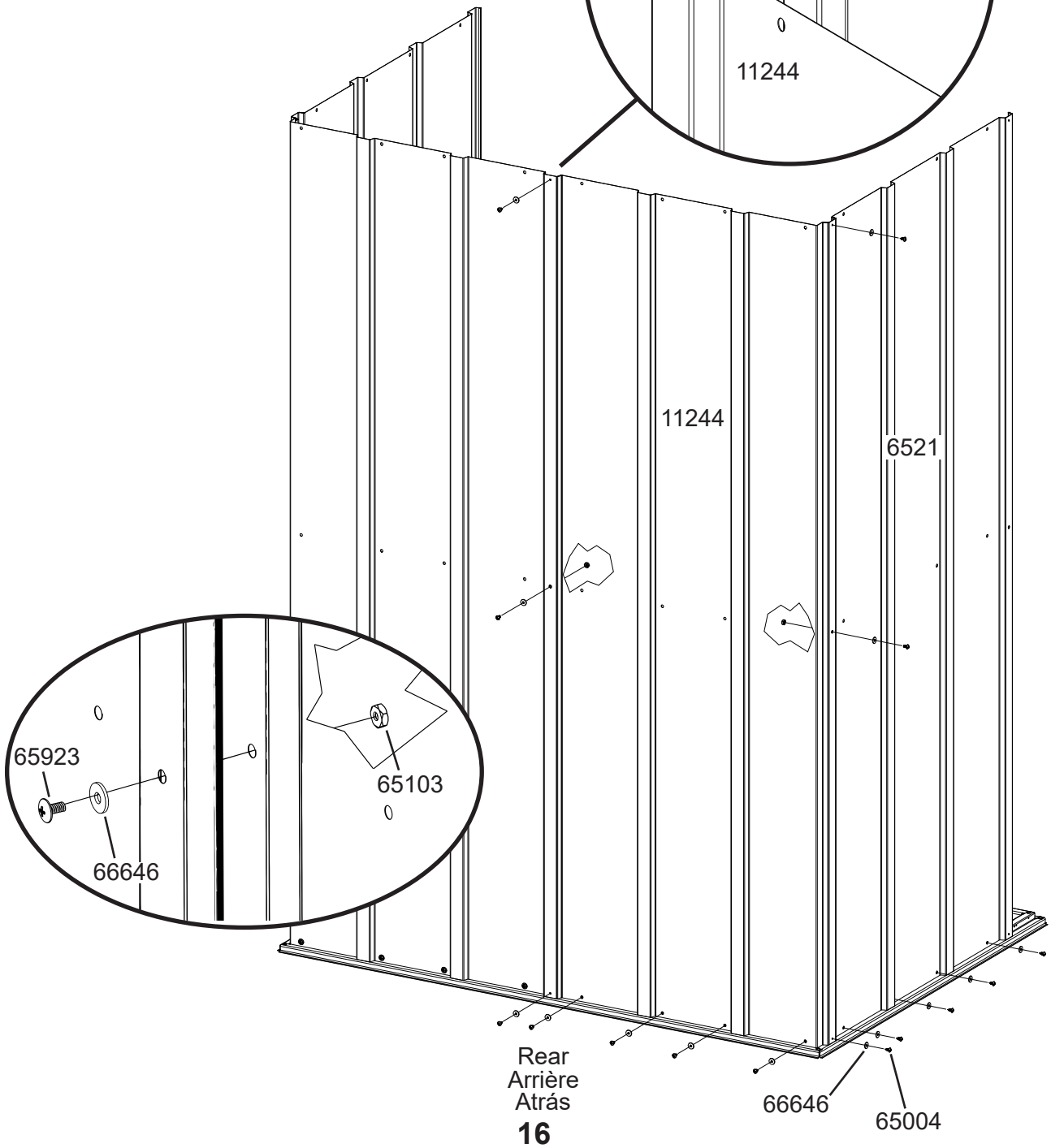
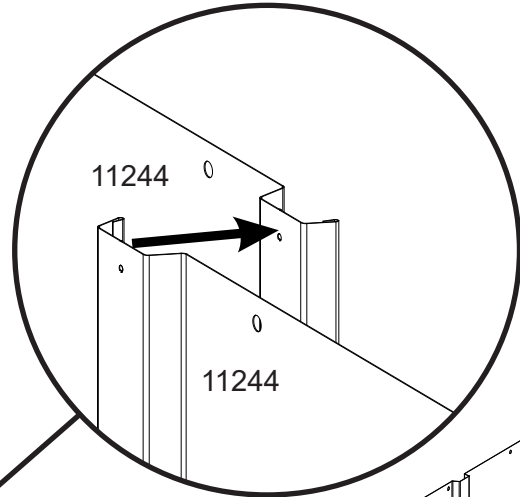
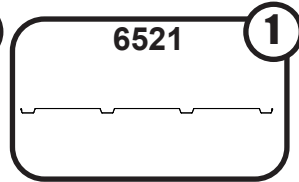
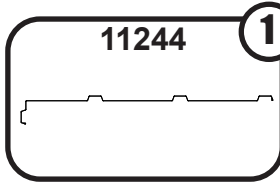
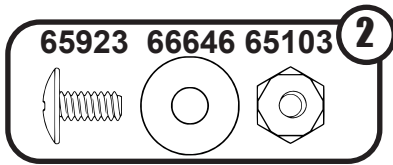
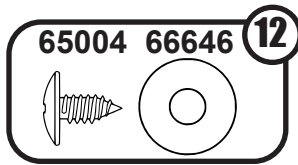

2: WALL PANELS

PANNEAUX DE MUR
PANELES DE LA PARED

EN,FR,SP-17KY

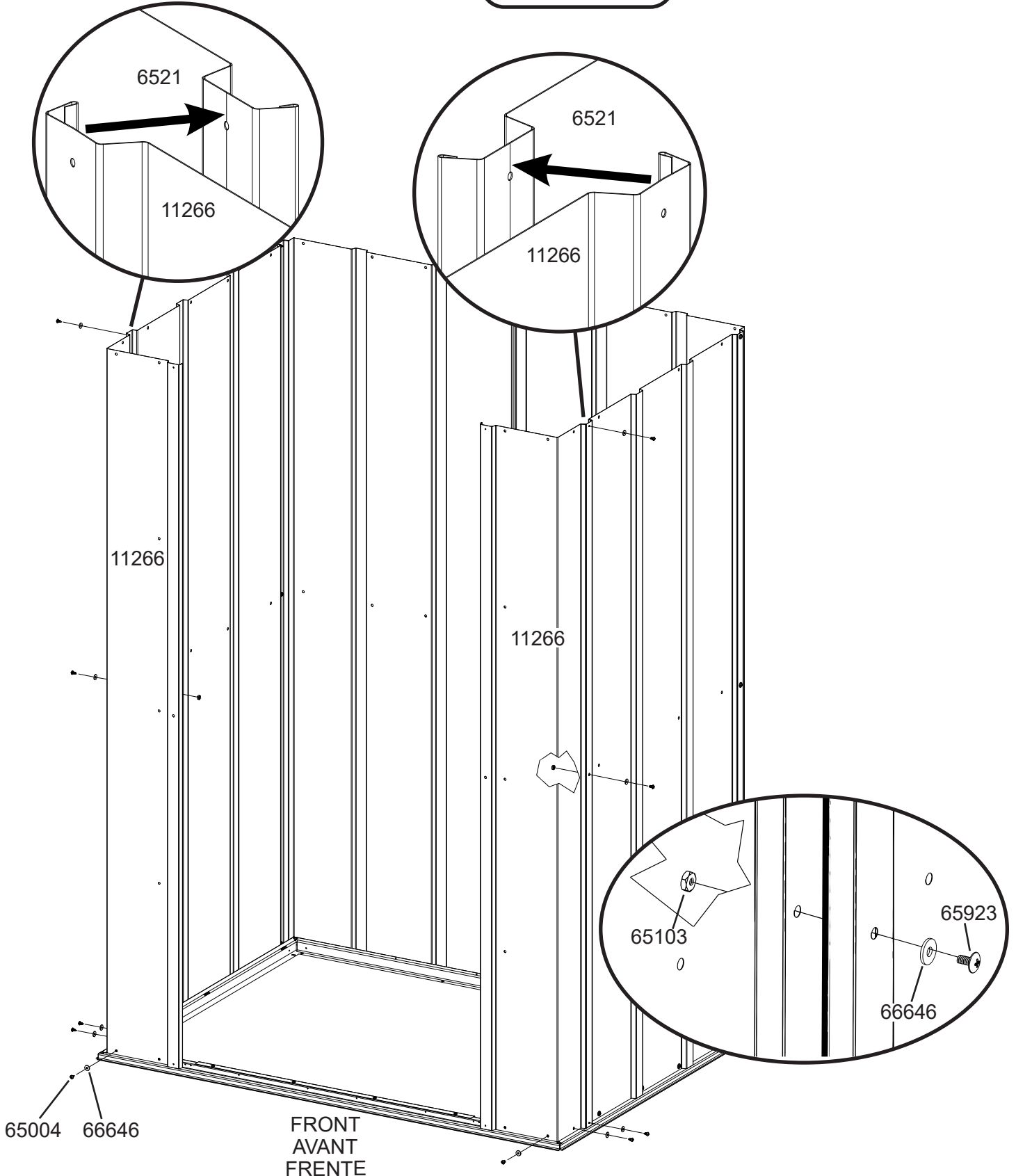
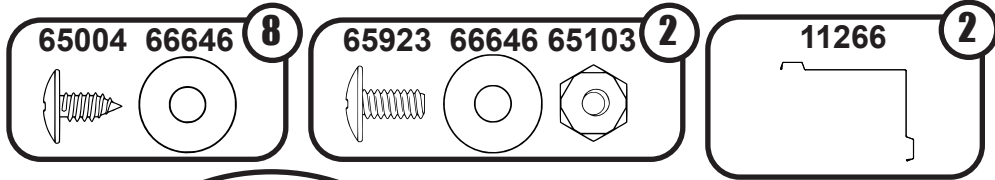

3: DOOR JAMB/LINTEL

JAMBAGE DE PORTE / LINTEAU
JAMBA DE LA PUERTA / DINTEL

EN,FR,SP-18KY

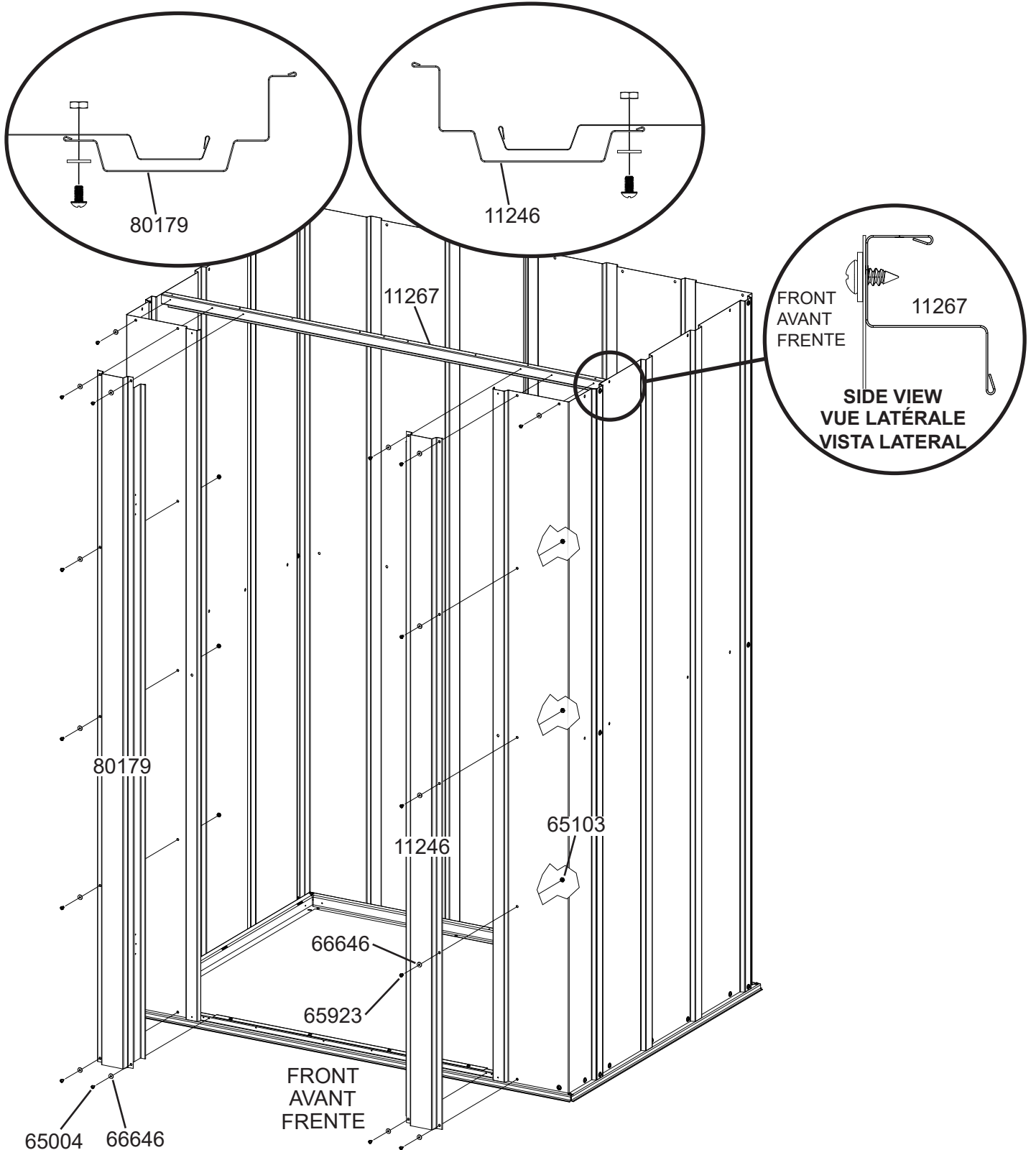
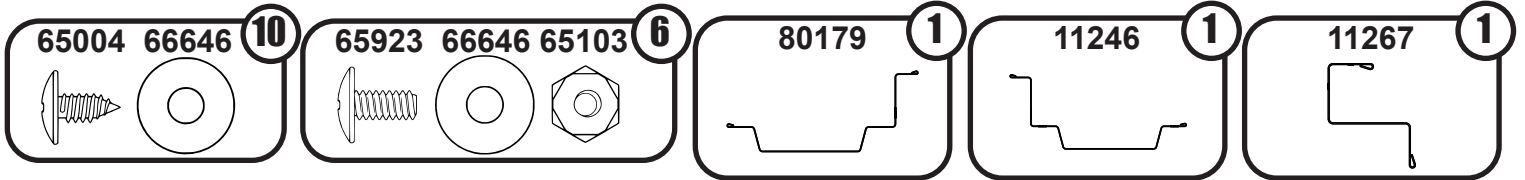

4: WALL ANGLE

CORNIÈRE DE MUR
ÁNGULO DE LA PARED

EN,FR,SP-19KY

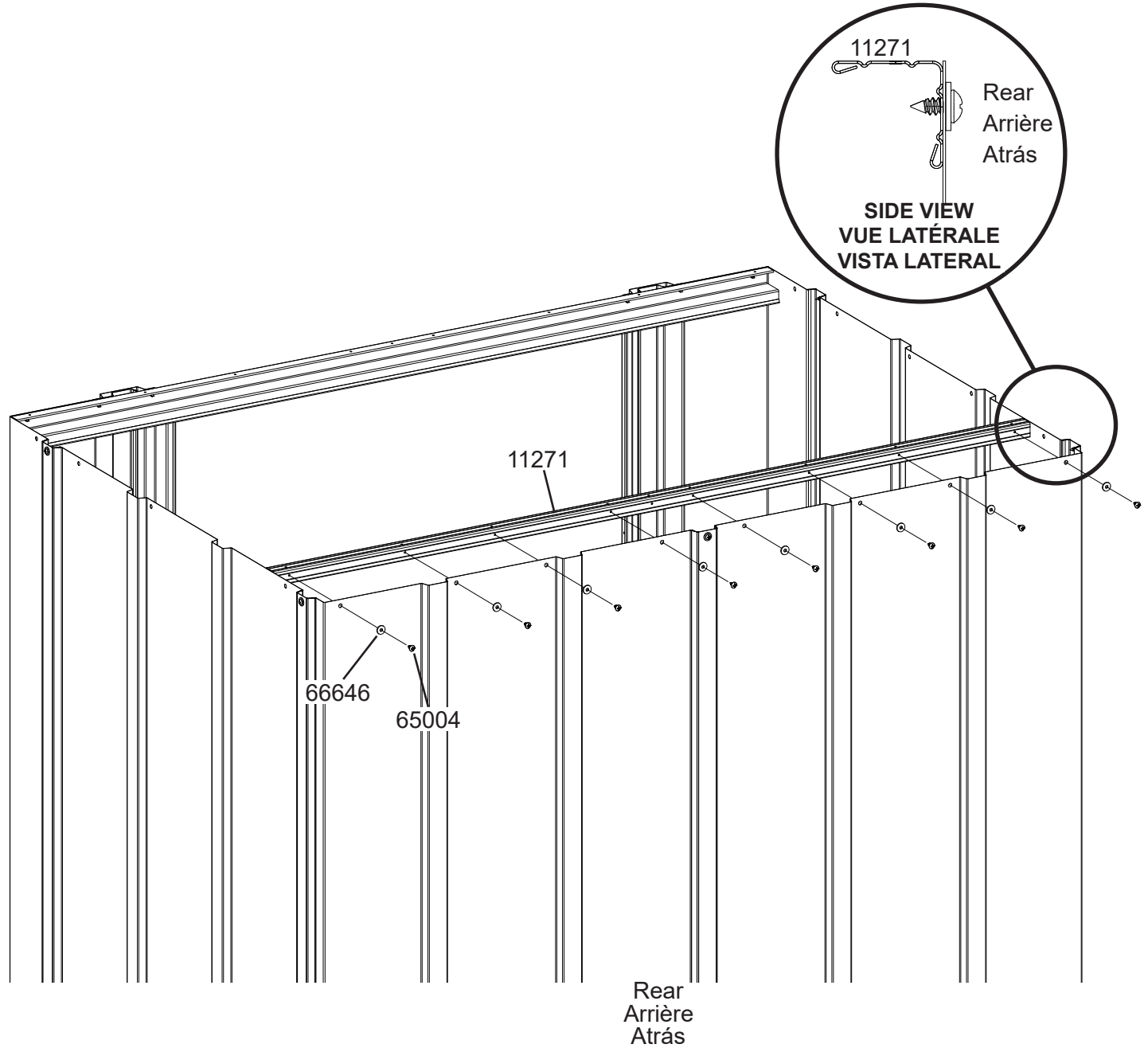
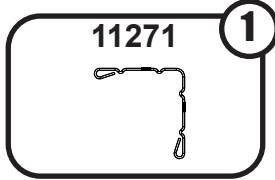
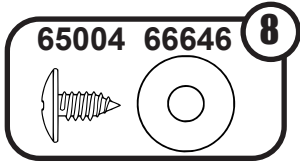

5: WALL CHANNEL

LONGERON DE MUR
CANALETA DE LA PARED

EN,FR,SP-20KY

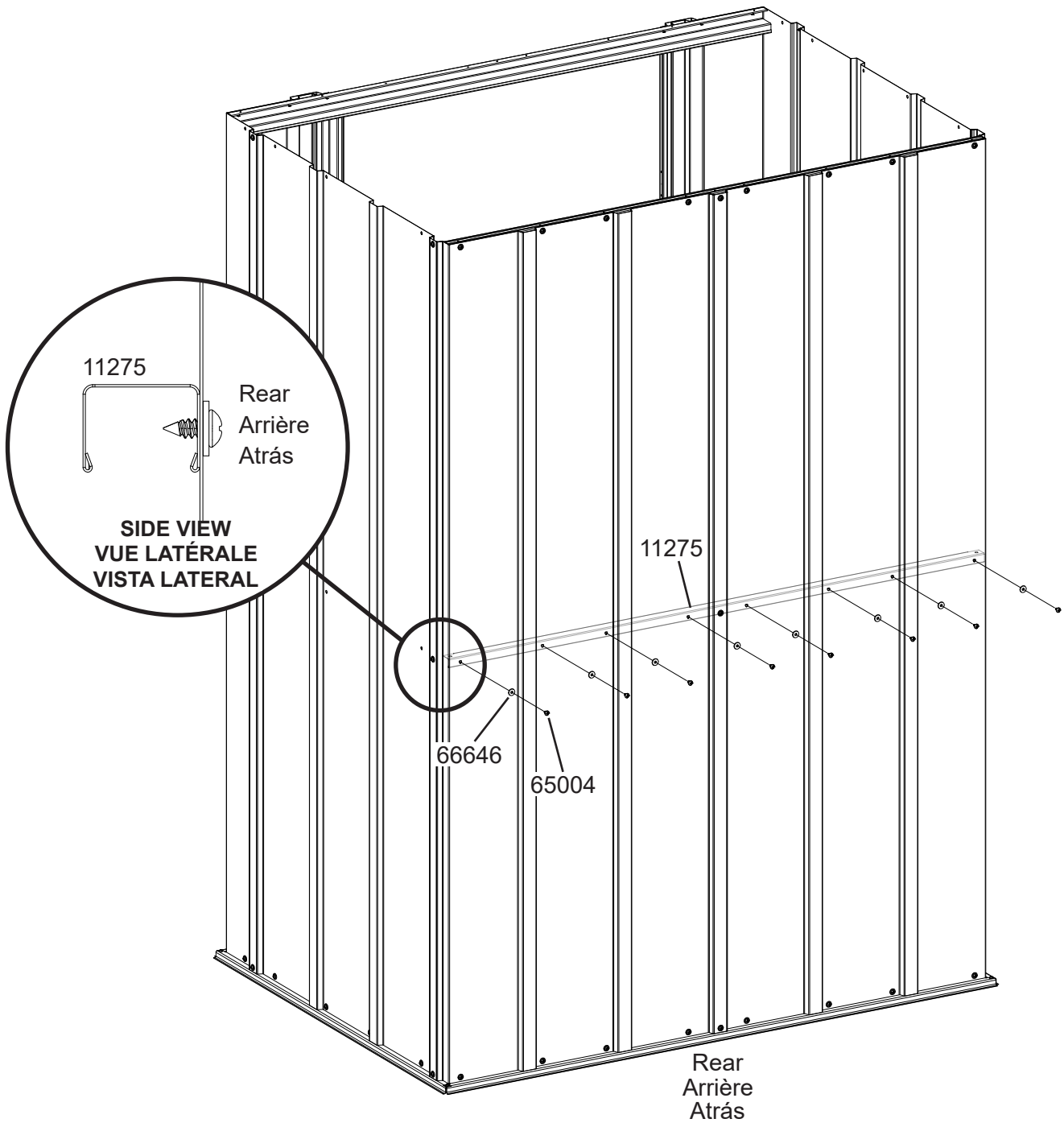
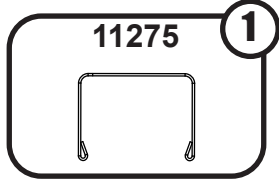
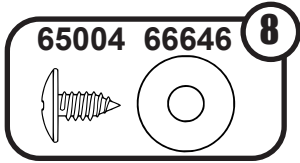

5: WALL CHANNEL

LONGERON DE MUR
CANALETA DE LA PARED

EN,FR,SP-21KY

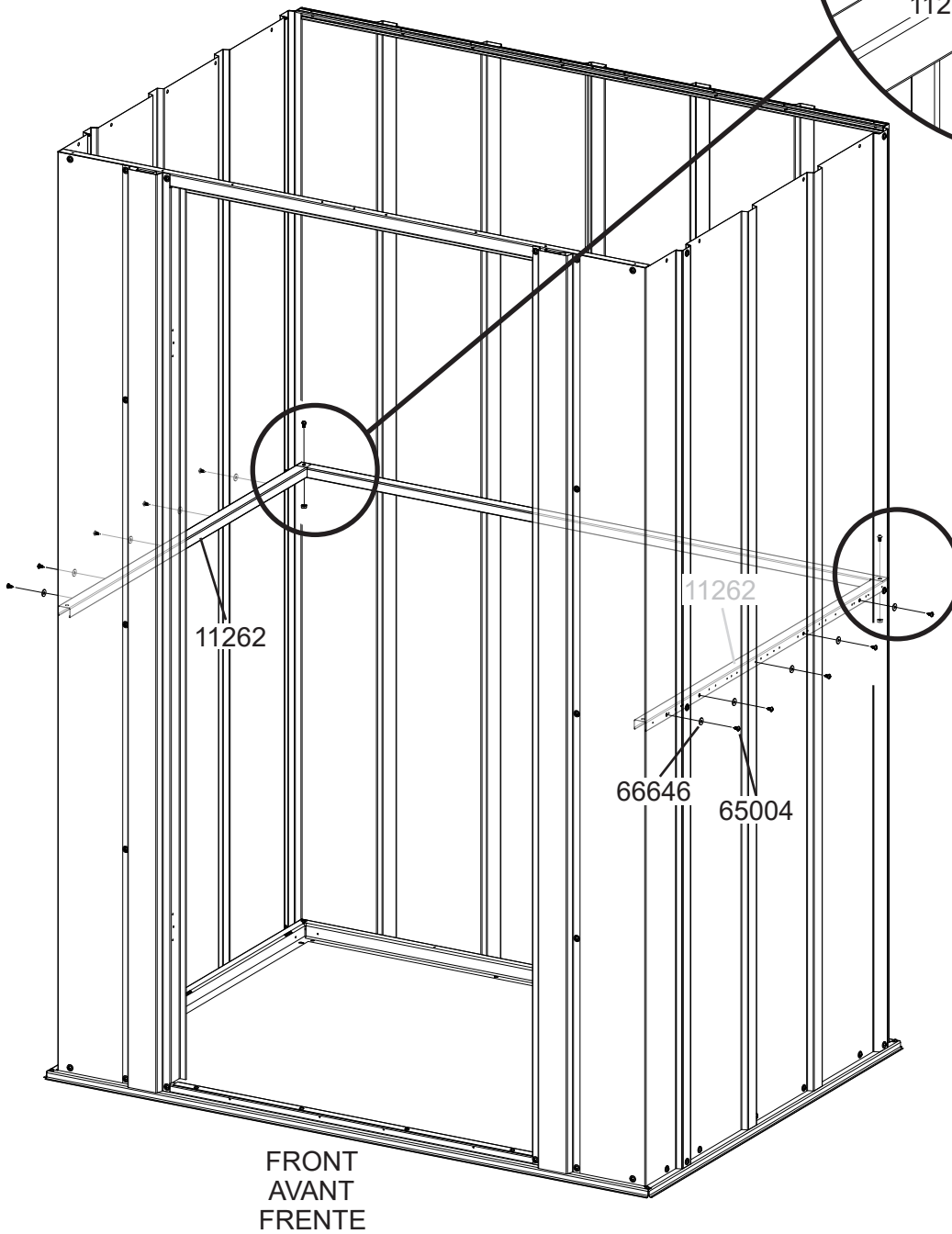
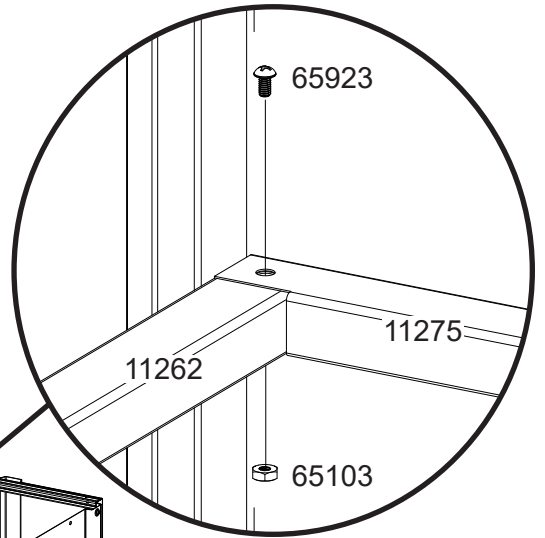
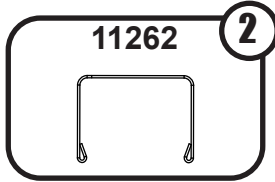
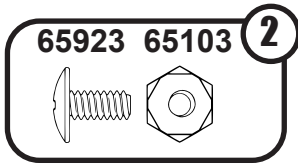
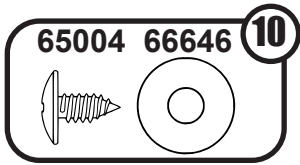

6: HEADER

TRAVERSE FRONTALE
DINTEL FRONTAL

EN,FR,SP-22KY

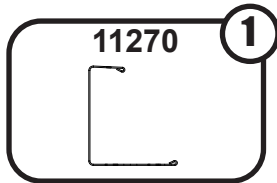
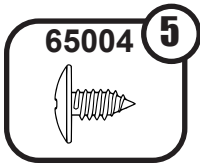

OPTION - A OPCIÓN - A

FOR OPTION B, SKIP AND GO TO PAGES 27 TO 31.

POUR L'OPTION B, SAUTEZ CETTE SECTION ET CONSULTEZ LES PAGES 27 À 31.

PARA LA OPCION B, SALTE ESTA PARTE Y CONSULTE LAS PÁGINAS 27 A 31.

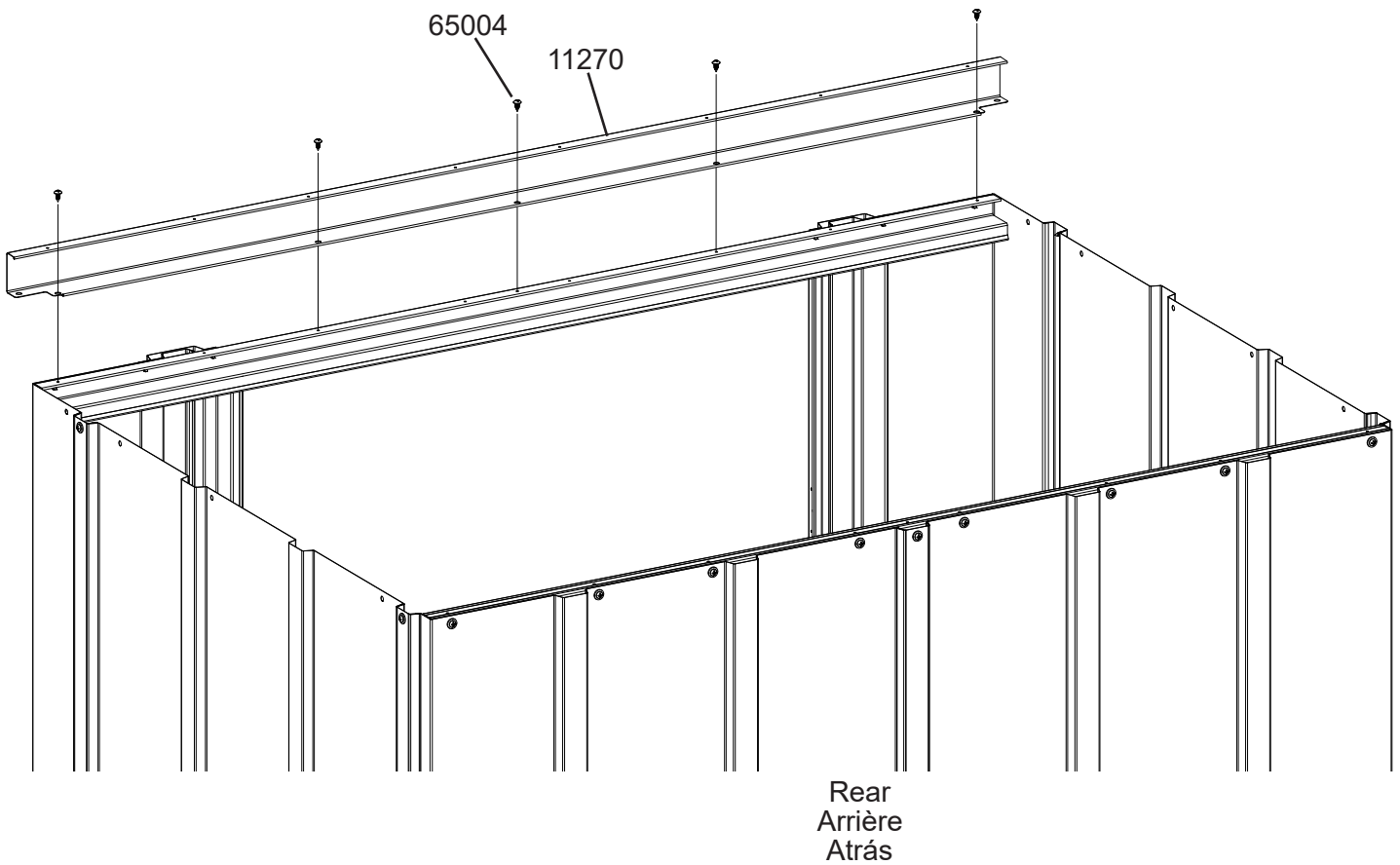

7: GABLES

PIGNON
GABLETE

EN,FR,SP-23KY

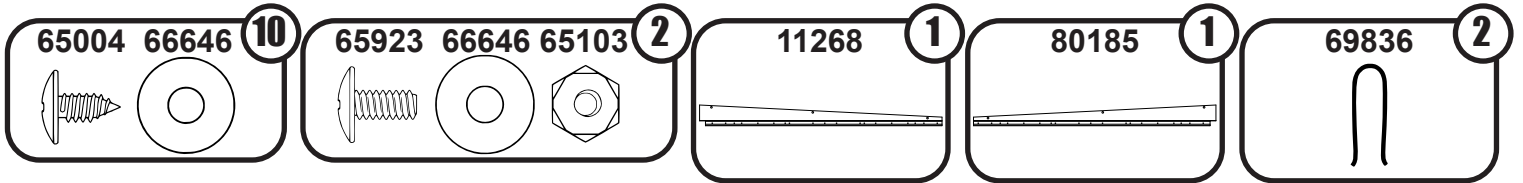

OPTION - A OPCIÓN - A

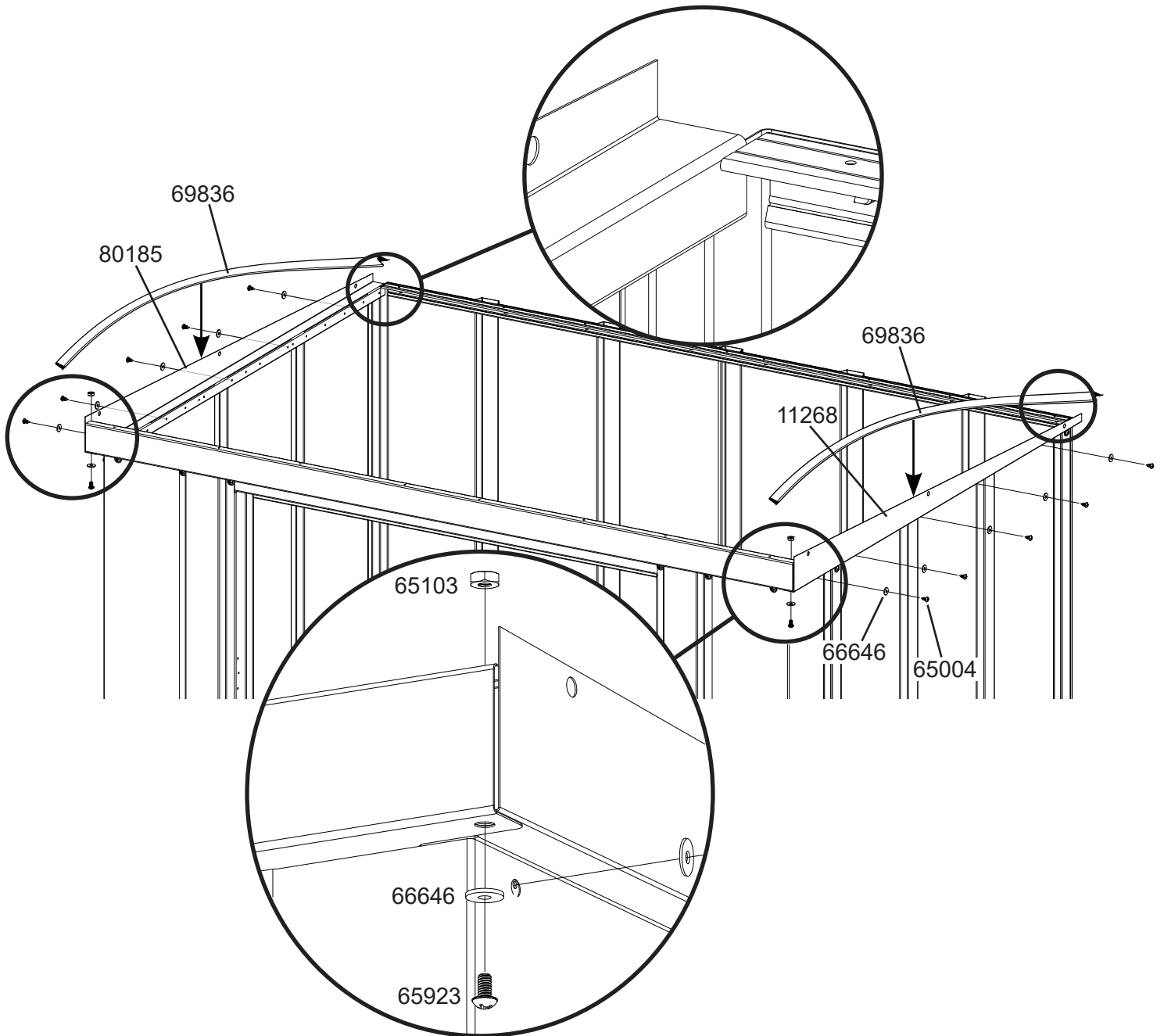

CAUTION:

To avoid mishap on the sharp edge the edge trim must remain in place on the top edge of the gable until right and left roof panels are in place.

PRUDENCE:

Pour éviter les accidents sur l'arête coupante de la garniture de bord, cette garniture doit rester en place sur le bord supérieur du pignon jusqu'à ce que les panneaux de toit droit et gauche soient en place.

ADVERTENCIA:

Para evitar un accidente en el borde filoso, el recuadro del borde debe quedar en su lugar en el borde superior del frontón hasta que los paneles izquierdo y derecho están colocados.

8: ROOF BEAM

POUTRE DE TOIT
VIGA DEL TECHO

EN,FR,SP-24KY

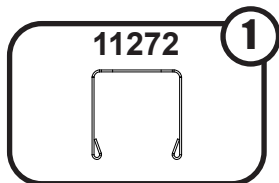

OPTION - A OPCIÓN - A

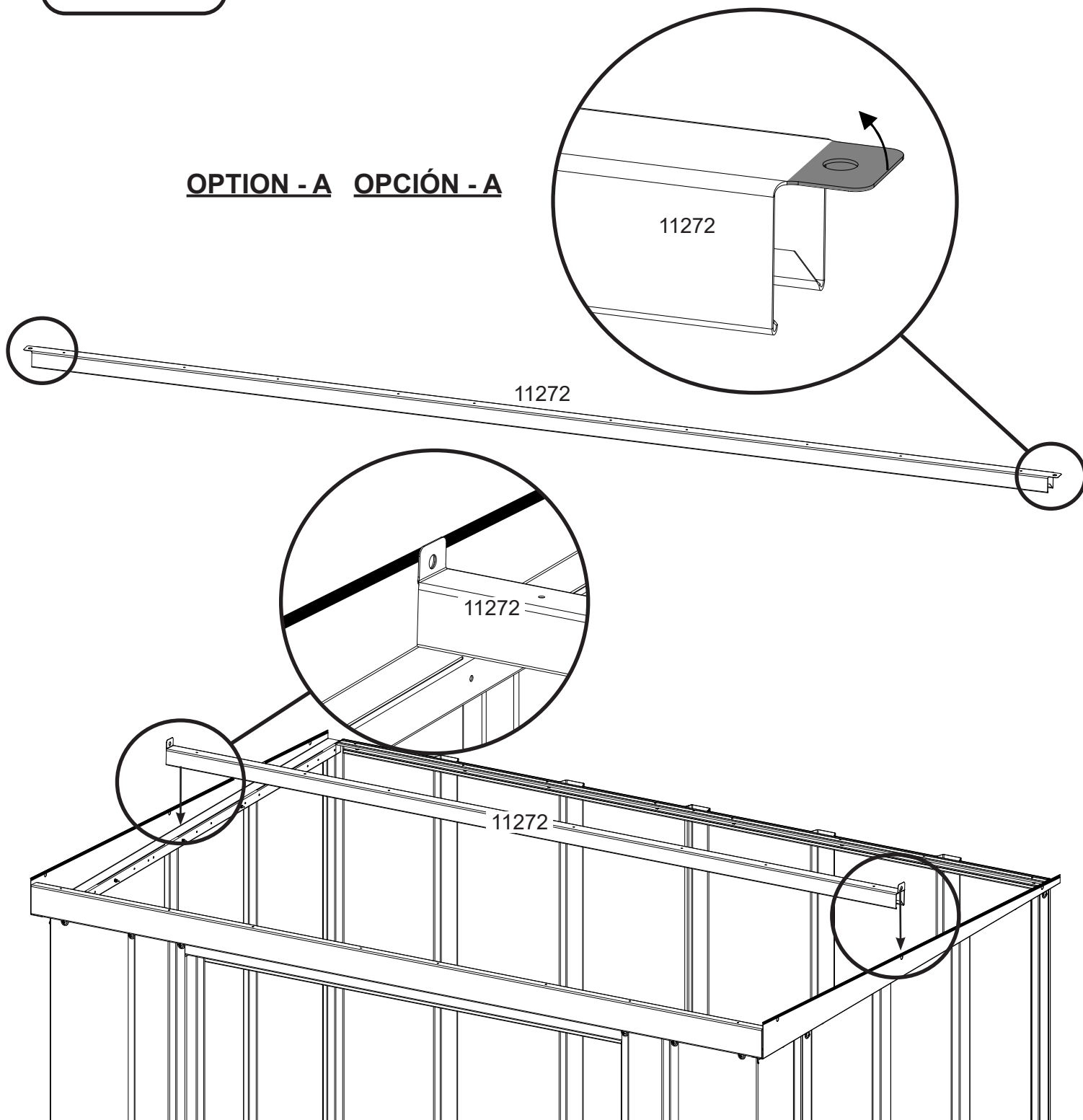

FRONT
AVANT
FRENTE

9: ROOF PANELS

PANNEAU DE TOIT
PANEL DEL TECHO

EN,FR,SP-25KY

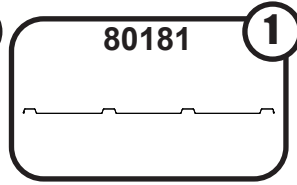
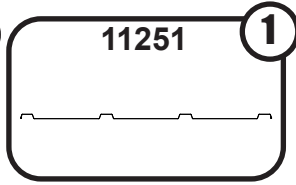
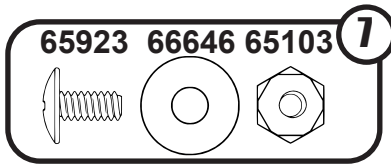
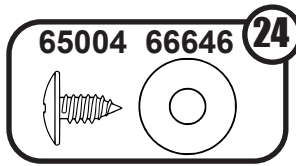

OPTION - A OPCIÓN - A

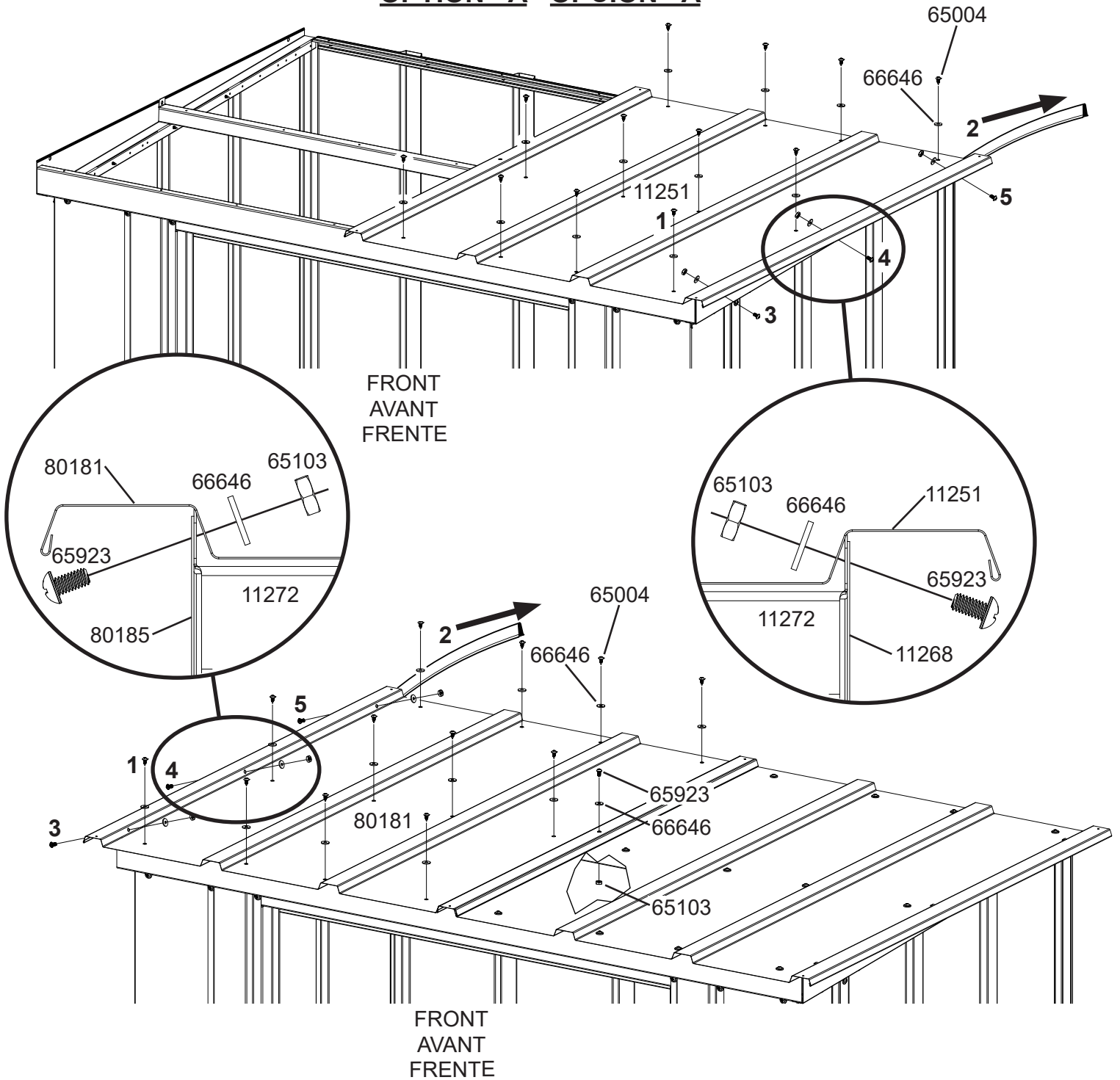

10: ROOF TRIM

GARNITURE DE TOIT
CONTRAMARCO DEL TECHO

EN,FR,SP-26KY

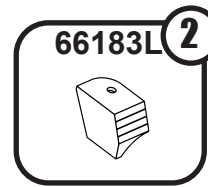
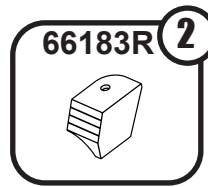
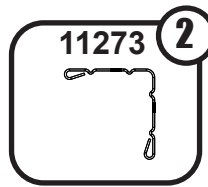
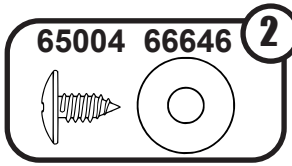
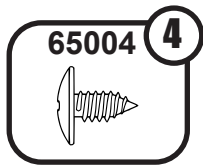

OPTION - A OPCIÓN - A

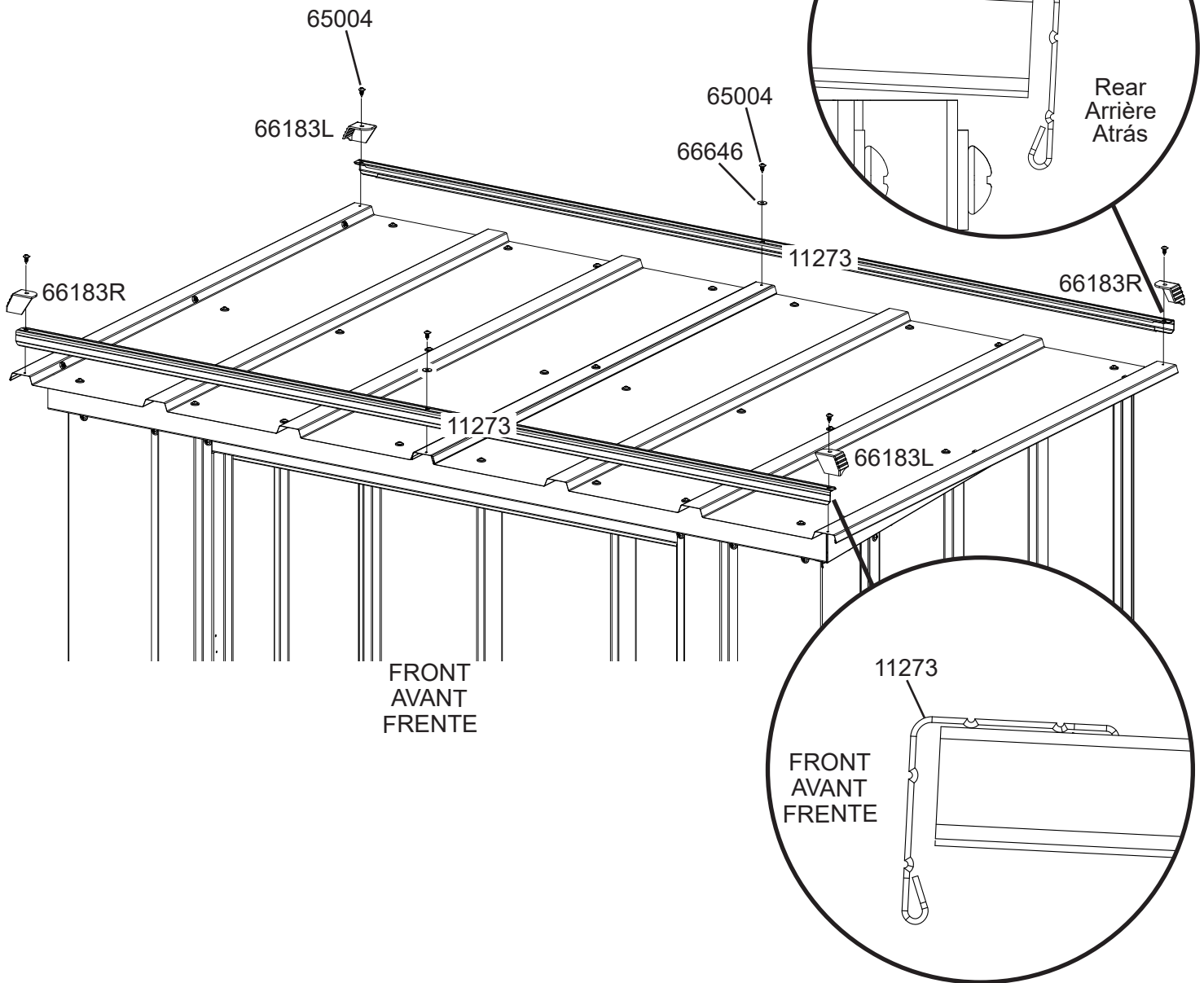

6: HEADER

TRAVERSE FRONTALE
DINTEL FRONTAL

EN,FR,SP-27KY

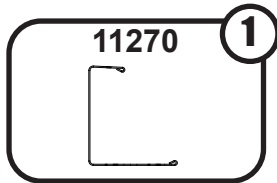
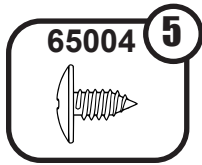

OPTION - B OPCIÓN - B

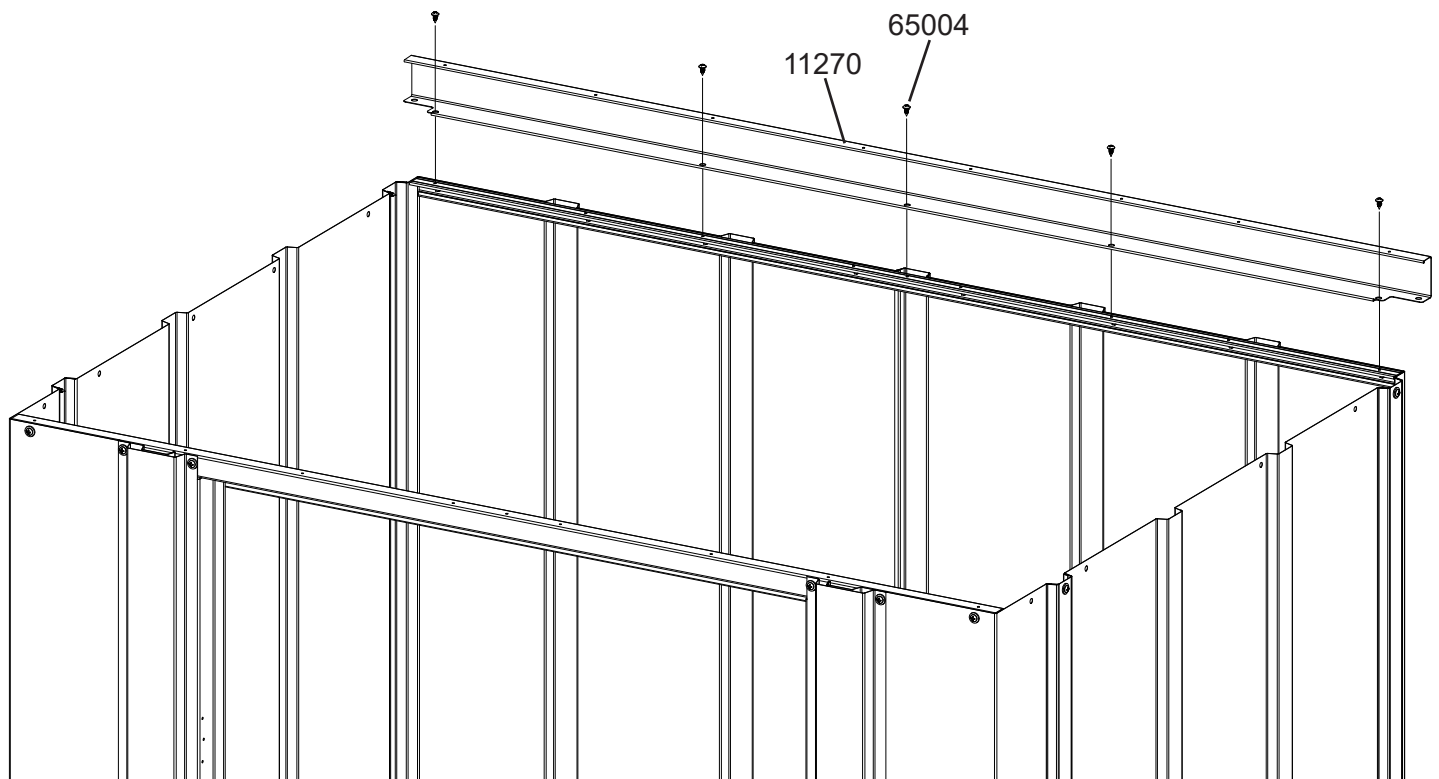

FRONT
AVANT
FRENTE

7: GABLES

PIGNON
GABLETE

EN,FR,SP-28KY

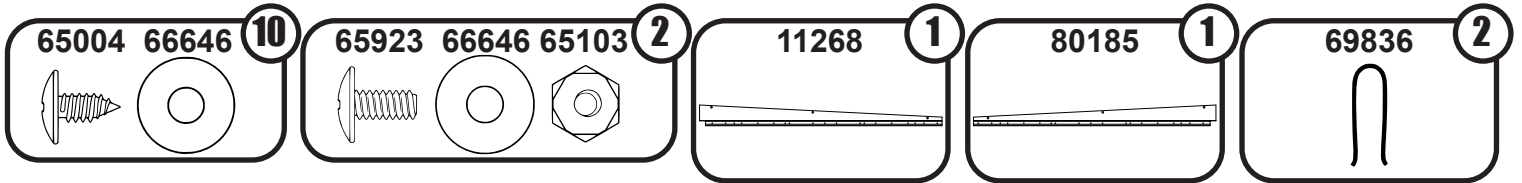

OPTION - B OPCIÓN - B

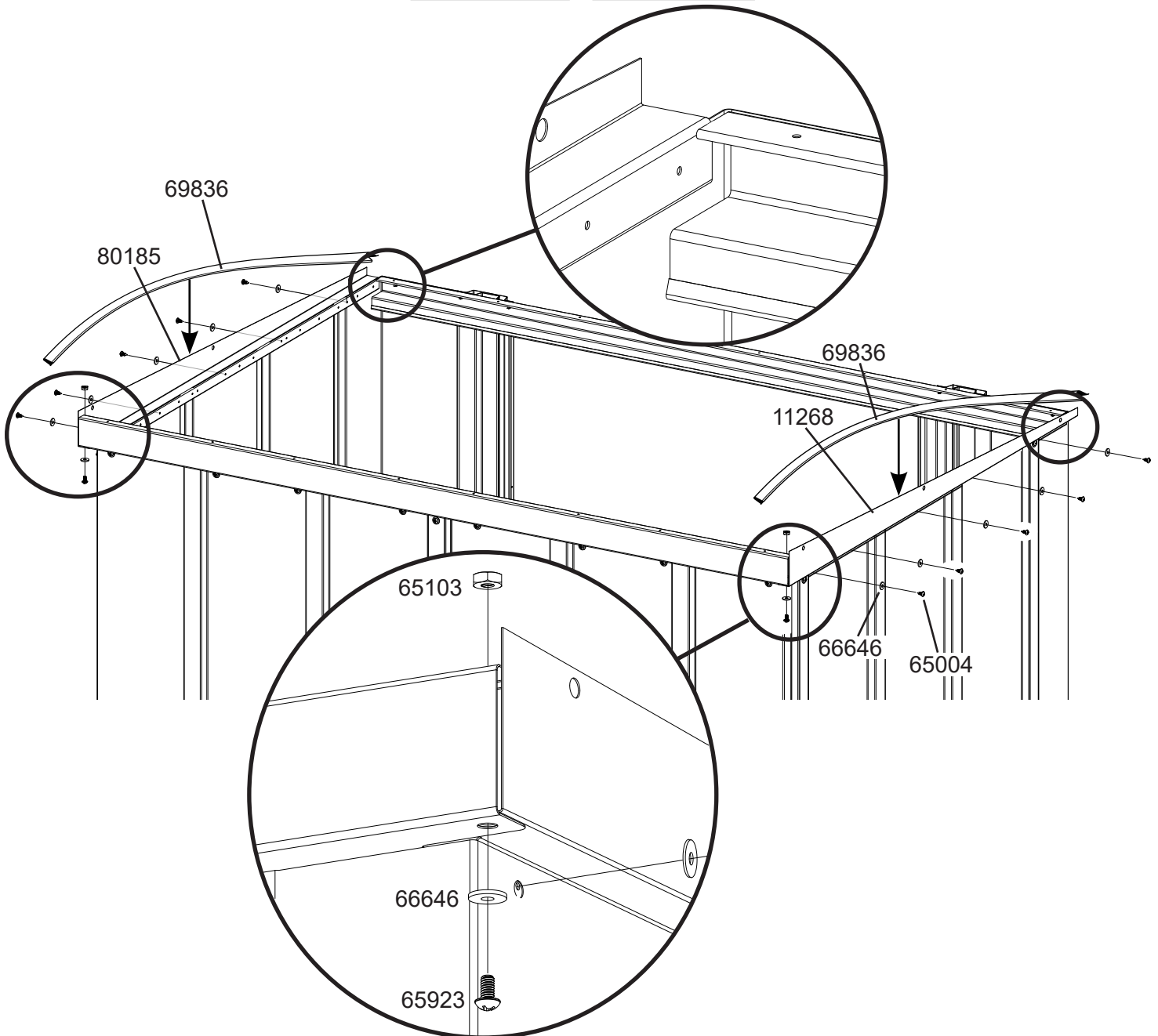

CAUTION:

To avoid mishap on the sharp edge the edge trim must remain in place on the top edge of the gable until right and left roof panels are in place.

PRUDENCE:

Pour éviter les accidents sur l'arête coupante de la garniture de bord, cette garniture doit rester en place sur le bord supérieur du pignon jusqu'à ce que les panneaux de toit droit et gauche soient en place.

ADVERTENCIA:

Para evitar un accidente en el borde filoso, el recuadro del borde debe quedar en su lugar en el borde superior del frontón hasta que los paneles izquierdo y derecho están colocados.

8: ROOF BEAM

POUTRE DE TOIT
VIGA DEL TECHO

EN,FR,SP-29KY

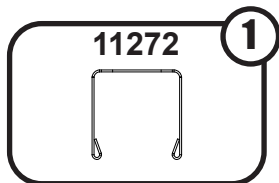

OPTION - B OPCIÓN - B

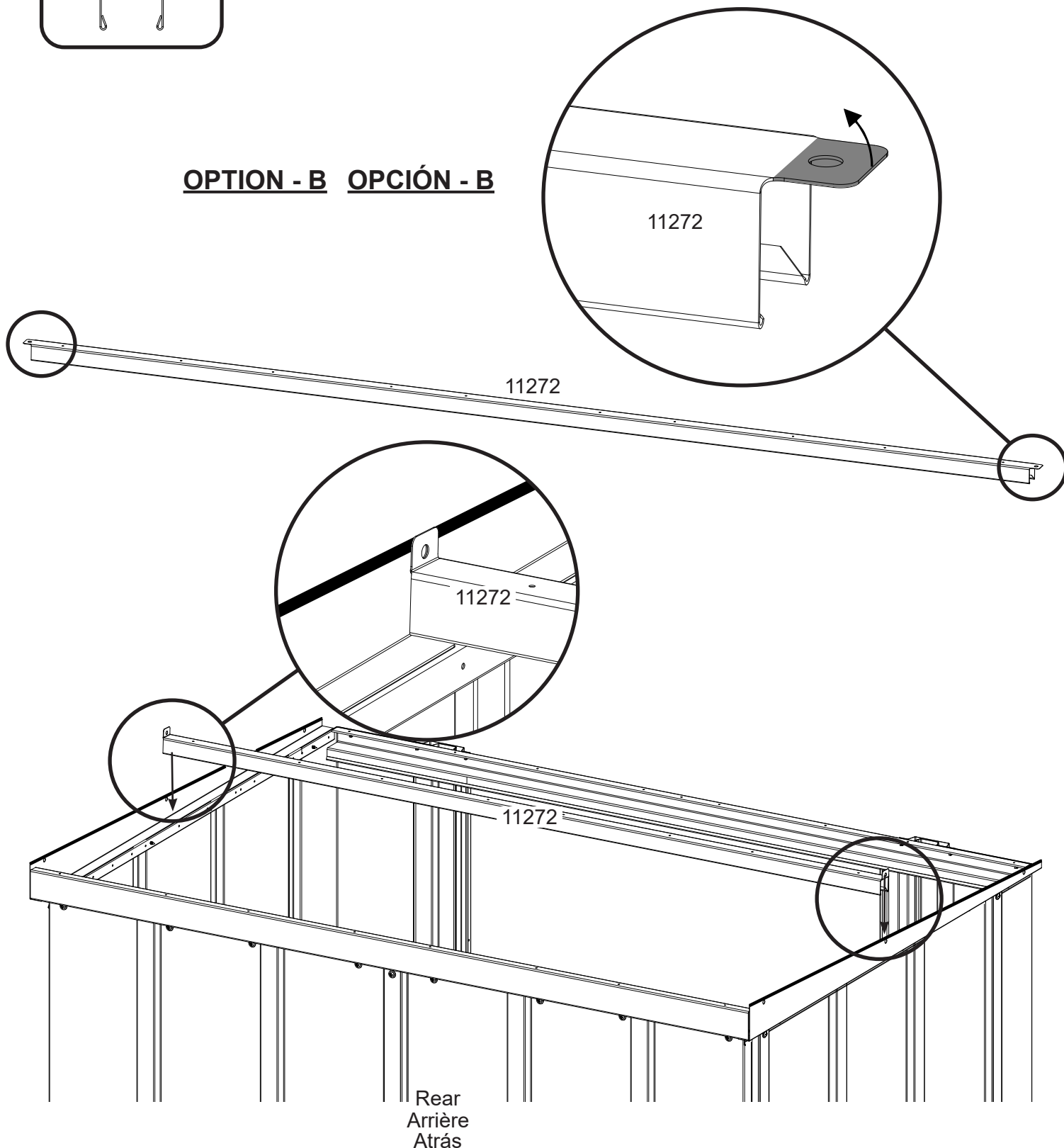

9: ROOF PANELS

PANNEAU DE TOIT
PANEL DEL TECHO

EN,FR,SP-30KY

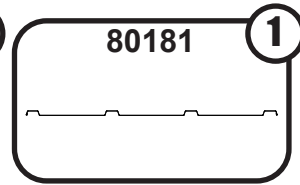
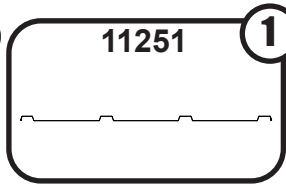
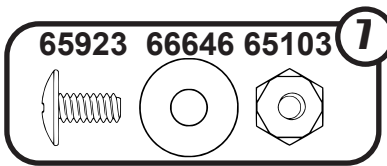
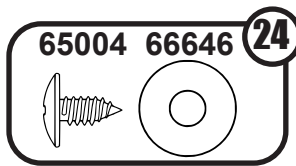

OPTION - B OPCIÓN - B

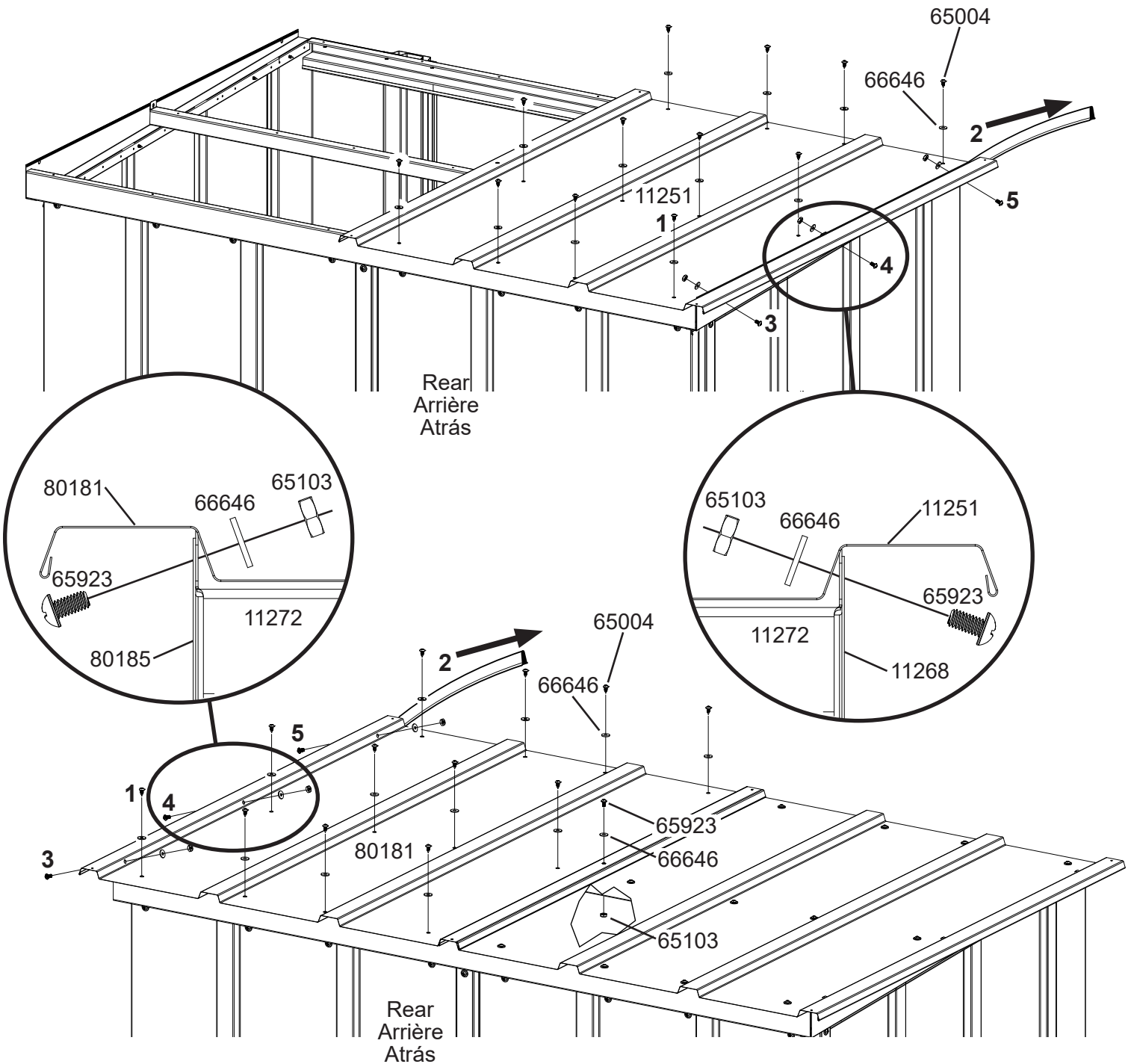

10: ROOF TRIM

GARNITURE DE TOIT
CONTRAMARCO DEL TECHO

EN,FR,SP-31KY

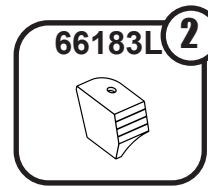
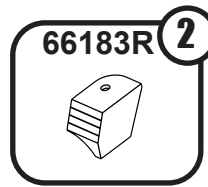
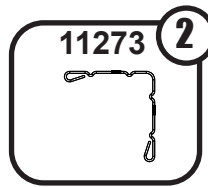
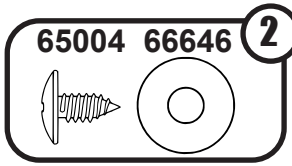
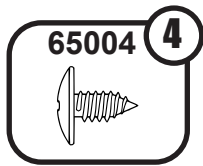

OPTION - B OPCIÓN - B

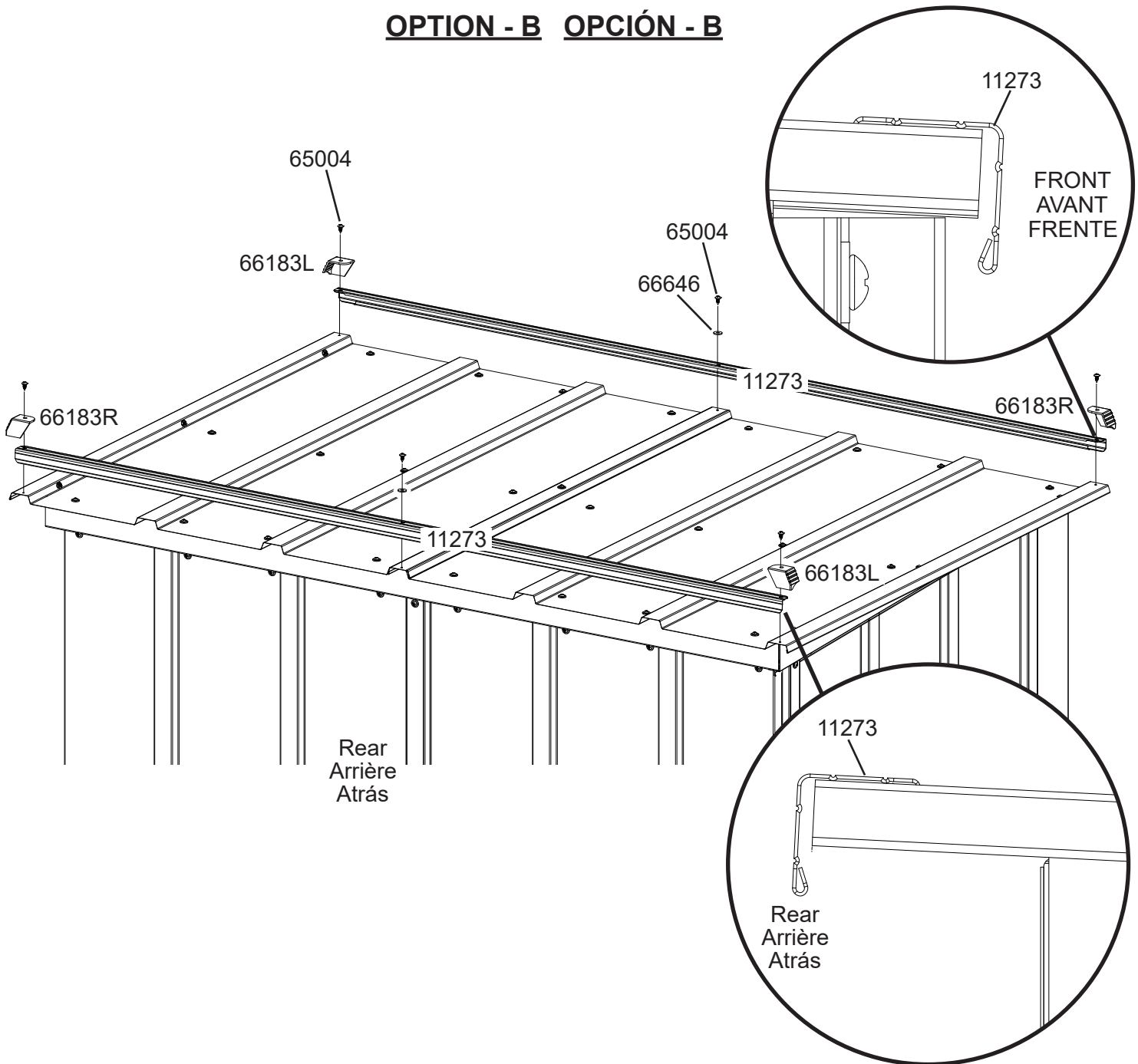

11: DOOR ASSEMBLY *PORTE ASSEMBLÉE* *ENSAMBLAJE DE LA PUERTA*

EN,FR,SP-32KY

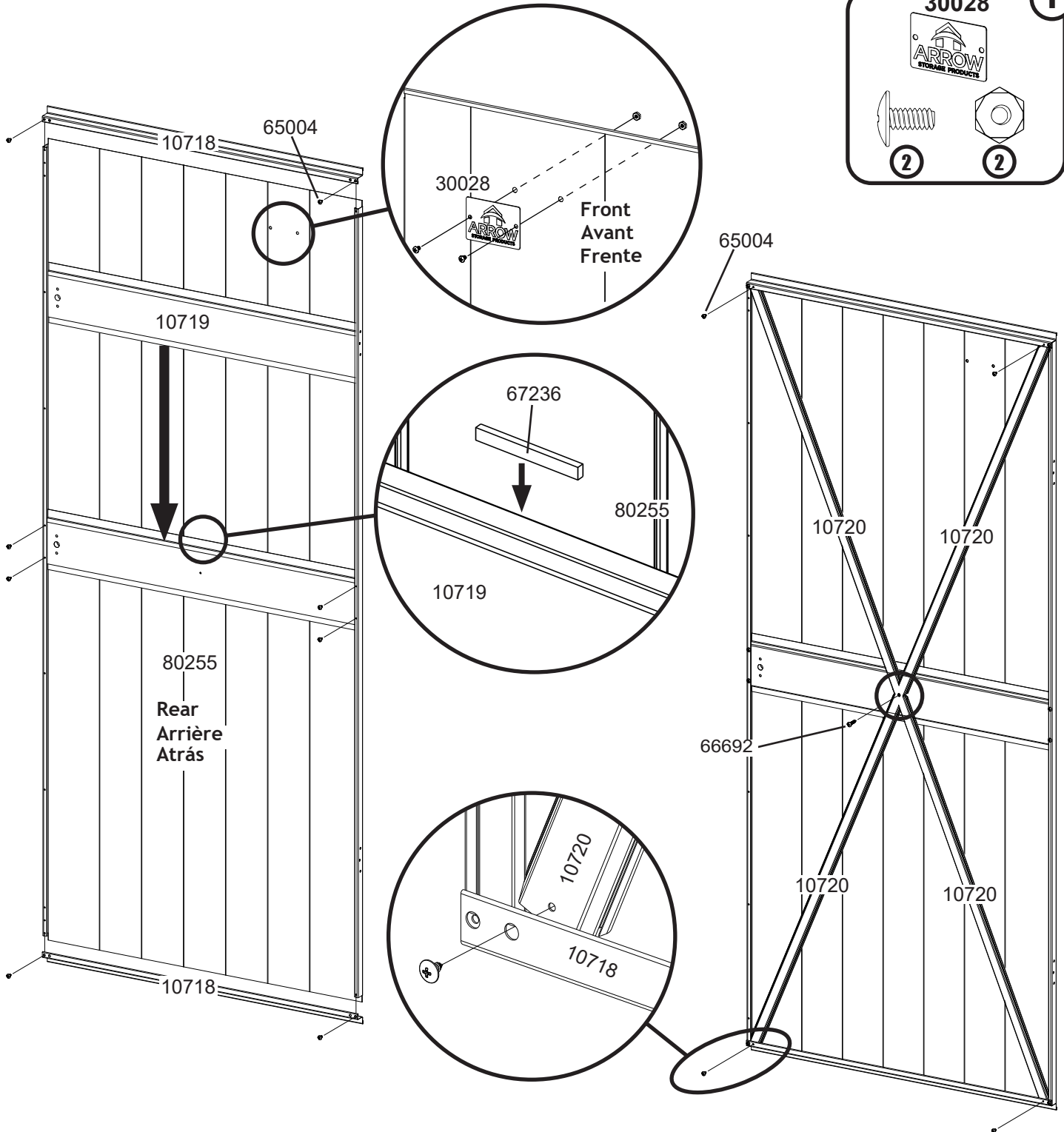
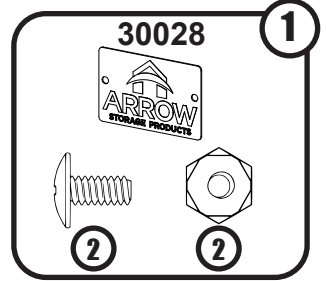
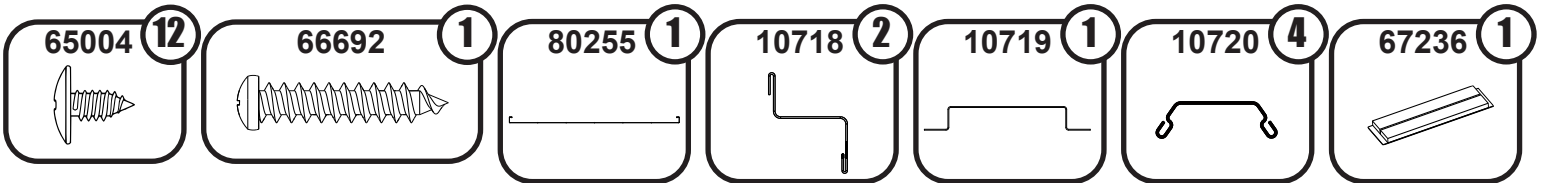

11: DOOR ASSEMBLY

PORTE ASSEMBLÉE
ENSAMBLAJE DE LA PUERTA

EN,FR,SP-33KY

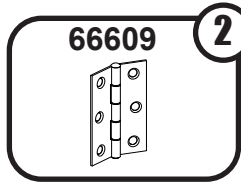
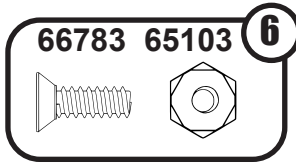

E - NOT REQUIRED 30000
E - n' est pas nécessaire
E - NO REQUERIDO

E
 (QTY/QTÉ/CANT: 2)

F
 (QTY/QTÉ/CANT: 2)

A
 Locking Handle
 Poignée verrouillable droite
 Manija de bloqueo derecha

C
 Shaft-Handle
 Arbre-poignée
 Eje del mango

D
 Latch
 Loquet
 Pestillo

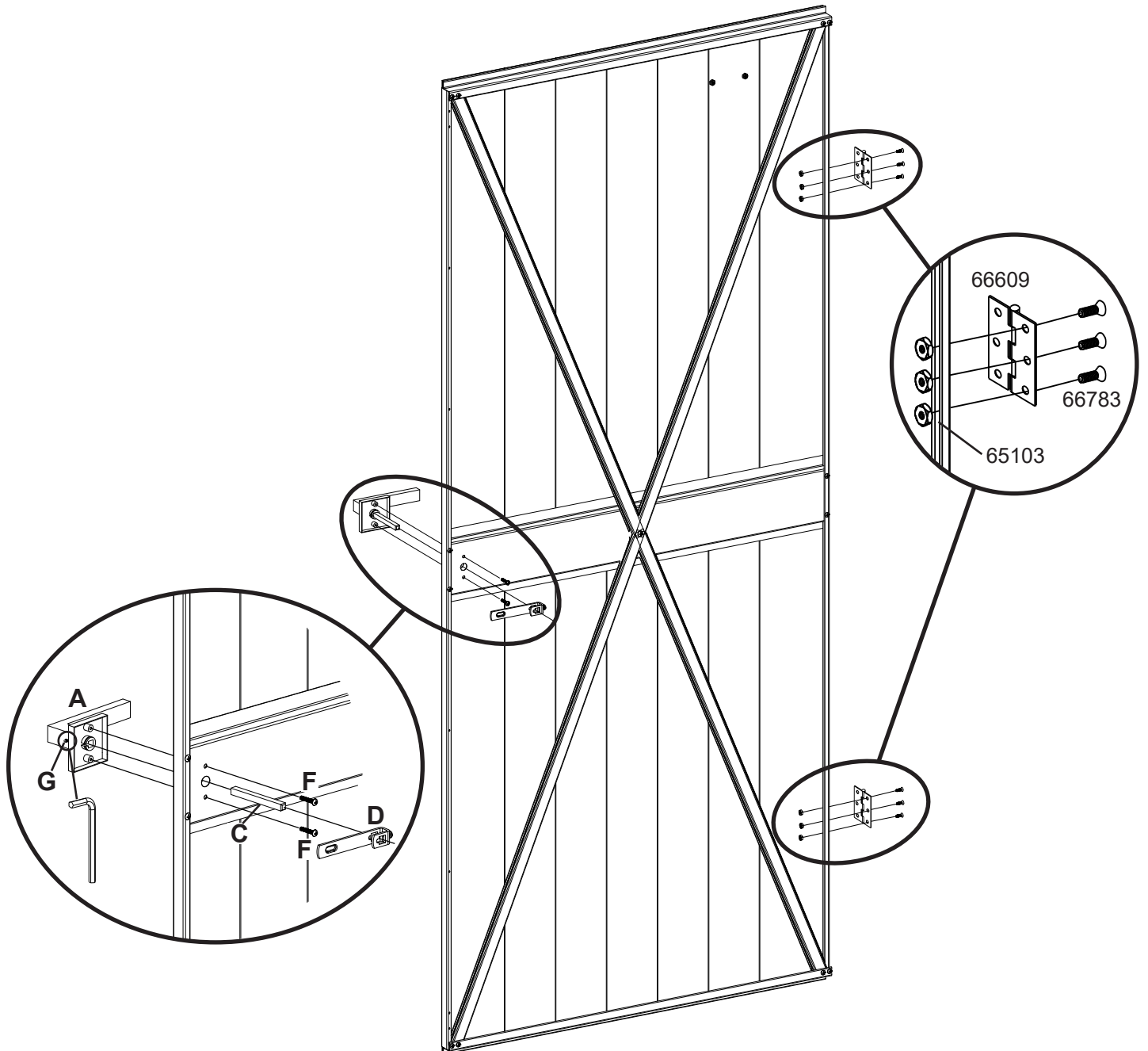

11: DOOR ASSEMBLY

PORTE ASSEMBLÉE

ENSAMBLAJE DE LA PUERTA

EN,FR,SP-34KY

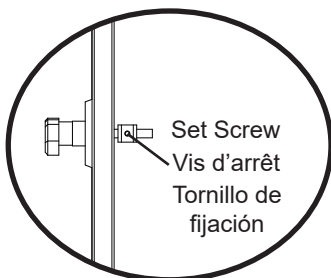
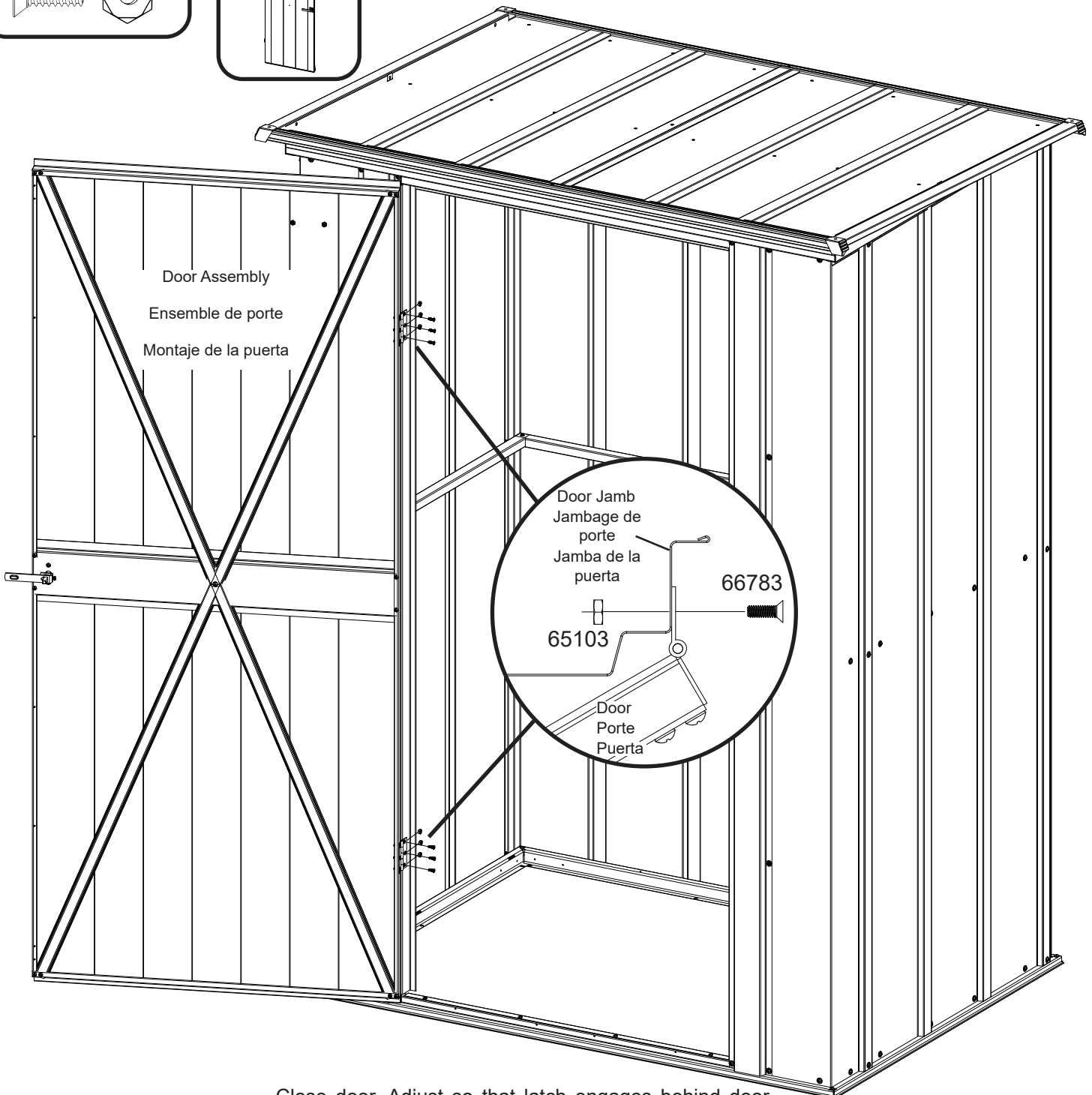
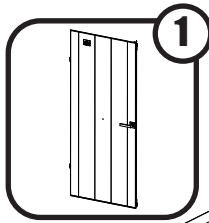
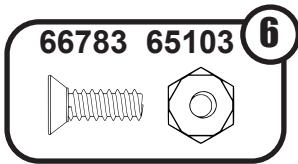

Close door. Adjust so that latch engages behind door jamb, then tighten set screw. The unit is locked. Turn key and remove.

Ajuster de manière à ce que le loquet s'enclenche derrière la porte jambage puis serrer la vis d'arrêt.

Cierre las puerta. Ajuste de manera que el cerrojo se enganche detrás de la puerta jambage, luego apriete el juego de tornillos. La unidad está trancada. Voltee la llave y la retira.

*** IMPORTANT ***

- *If you have swing doors, they must hang and swing level before anchoring building.*
- *Anchor your building at this time. Use appropriate 1/4"(6mm) X 1 1/2"(38,1mm) length hardware.*
- *Please take a moment to ensure that the building is installed in accordance with these instructions and with all applicable regulations.*
- *The entire floor frame **MUST** be securely anchored once the building is erected.*

*** IMPORTANT ***

- *Si l'abri comporte des portes battantes, vérifier qu'elles sont accrochées de niveau et pivotent librement avant d'ancre l'ouvrage.*
- *Ancrez votre bâtiment en ce moment. Utilisez une longueur appropriée de 1/4 po (6 mm) X 1 1/2 po (38,1 mm) Matériel.*
- *Veiller à bien s'assurer que l'abri est installé conformément aux présentes instructions et à toute la réglementation en vigueur.*
- *Le cadre de plancher entier doit **IMPÉRATIVEMENT** être solidement ancré une fois que l'abri est assemblé.*

*** IMPORTANTE ***

- *Si tiene puertas vaivén, estas deben colgar y moverse en forma pareja antes de sujetar el cobertizo.*
- *Ancle su edificio en este momento. Use una herramienta apropiada de 1/4 "(6 mm) X 1 1/2" (38,1 mm) de longitud.*
- *Dedique unos minutos a asegurarse de que la estructura está instalada de acuerdo con estas instrucciones y con las reglamentaciones vigentes.*
- *Se **DEBE** anclar todo el tirante del piso cuando la estructura está erguida.*

